

BUBBLE TRAP

Effective, in-line removal of bubbles

- Pressure rated up to 30 psi
- Effective de-bubbling of aqueous solutions

The Omnifit® Bubble Trap effectively removes bubbles from aqueous solutions. The unit is quickly and easily connected in-line using the 1/4"-28 UNF female threaded ports and fittings such as Omni-Lok™. Spare membranes are available.

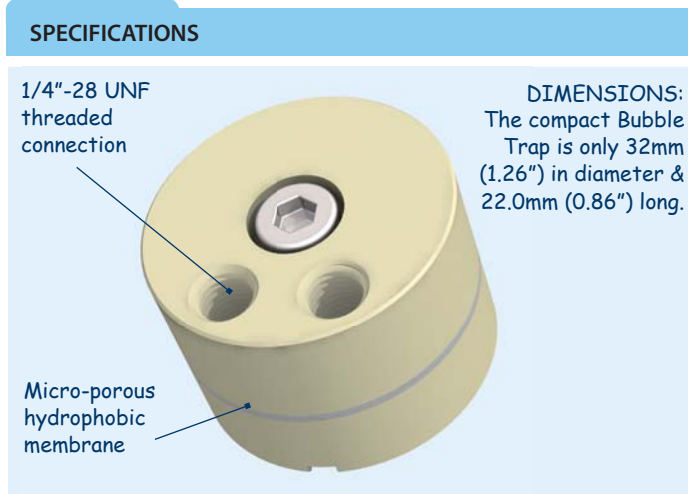

Operation

When a fluid containing bubbles flows through the unit, the bubbles are forced through a micro-porous, hydrophobic membrane whilst aqueous fluid is retained within the Trap. Because the membrane function depends on its hydrophobicity, the Trap is only suitable for use with aqueous systems and NOT with organic solvents.

Flow

Maximum flow rate is dependent upon the amount of bubbles in the liquid. Typical operating range is 0.5 - 2.0ml/min, but up to 6ml/min can be achieved if few bubbles are present in the liquid.

Pressure

The unit is pressure rated up to 30psi. De-bubbling is effected under positive pressure. It is not possible to pull liquid through the unit under vacuum as this would introduce bubbles into the fluid. If the system back-pressure is insufficient for the unit to function, a length of tube can be fitted on the outlet side to create more back-pressure.

Maintenance

The lifetime of the membranes strongly depends on the kind of fluid being used. For pure water, the lifetime may be several months or years. If buffer solutions are used, the life will be reduced and it is advisable to flush the unit with de-ionized/distilled water after use to prevent salt crystals forming.

INLINE BUBBLE TRAP					
PART NUMBER	FILTER MATERIAL	POROSITY	CONNECTION 1	CONNECTION 2	QTY
006BT	PTFE	25 µm	1/4•28 M	1/4•28 F	ea

REPLACEMENT FILTER ELEMENTS			
PART NUMBER	FILTER MATERIAL	POROSITY	QTY
006BTF	PTFE	25 µm	ea

IN-LINE FILTERS

Inert microporous filters remove particulates and protect solenoid valves and sensitive instruments

- Inert flow path with all PTFE wetted parts
- Simple filter replacement
- Fluid distribution pattern for optimum filtration
- Easy installation in-line

These all-PTFE in-line filter units offer a highly inert flow path suitable to applications involving aggressive and high-purity fluids. The filters ensure that particulates are removed from the medium, protecting downstream instrumentation from particulate damage. PTFE solenoid valves for example, are inherently susceptible to damage from particulates.

Each filter unit comprises an all PTFE housing which holds a removable 100µm PTFE filter. The filter element can be easily and economically replaced, making the filters an excellent investment to ensure the long-term functioning of your solenoid valves and analytical instruments. A distribution pattern machined into the filter housing ensures that liquid is spread across the entire filter surface, giving maximum usage of the filter area. This distribution pattern is present on both sides of the filter housing, meaning that the filters are bi-directional with either port able to act as the inlet. However, once installed, flow direction should not be reversed, as contamination may result.

INLINE FILTERS					
PART NUMBER	FILTER MATERIAL	POROSITY	CONNECTION 1	CONNECTION 2	QTY
003303	PTFE	100µm	Omnifit® cap	Omnifit® cap	ea
003304	PTFE	25µm	Barb	Barb	ea
003305	PTFE	25µm	1/4•28 F	1/4•28 F	ea

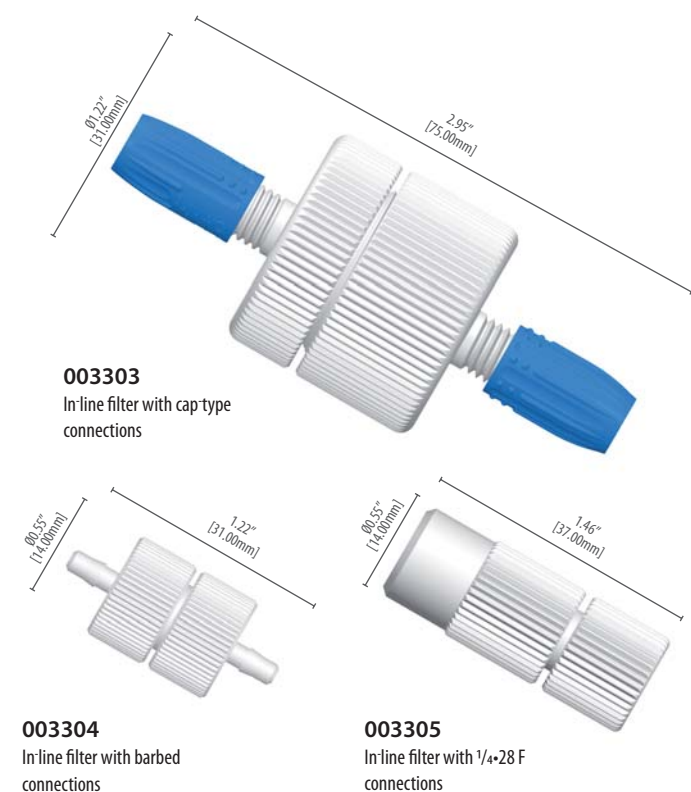

INSTALLATION INSTRUCTIONS

Series 075RV relief valve

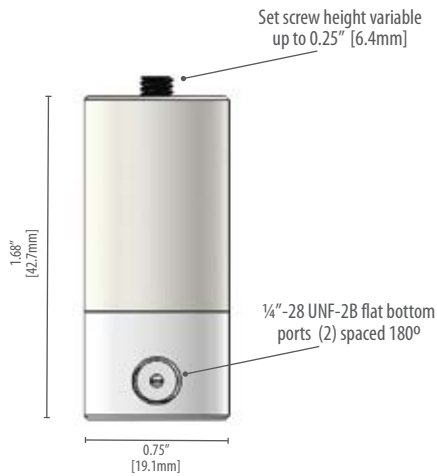

Series 075RS relief valve with solenoid

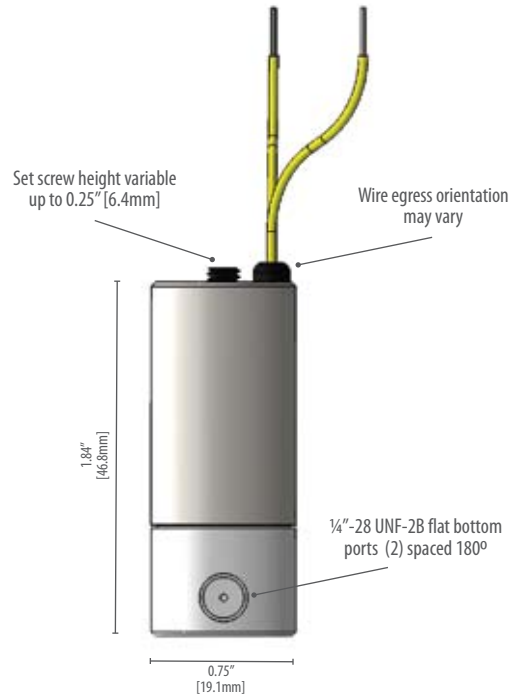

Ordering Information:

Series 075RV relief valve

Spring loaded only

PART NO.	SET PRESSURE (psig)	BODY MATERIAL	DIAPHRAGM MATERIAL
075RV-62-20	20	PPS	FFKM
075RV-62-35	35	PPS	FFKM
075RV-62-60	60	PPS	FFKM
075RV-62-85	85	PPS	FFKM
075RV-62-110	110	PPS	FFKM
075RV-62-150	150	PPS	FFKM

Series 075RS relief valve

Spring loaded with 12VDC solenoid

PART NO.	SET PRESSURE (psig)	BODY MATERIAL	DIAPHRAGM MATERIAL
075RS12-62-20	20	PPS	FFKM
075RS12-62-35	35	PPS	FFKM
075RS12-62-60	60	PPS	FFKM
075RS12-62-85	85	PPS	FFKM
075RS12-62-110	110	PPS	FFKM
075RS12-62-150	150	PPS	FFKM

NOTE: For 24 VDC, replace 075RS12 with 075RS24 in any of the part numbers listed.

**BIO-CHEM
FLUIDICS**

www.biochemfluidics.com

HRoMalytic +61(0)3 9762 2034 09
 AUSTRALIAN Distributors **ECHnology** www.chromtech.net.au