

OPERATION MANUAL

FOR QL HYDROGEN GENERATORS

(QL-M150)

Shandong Saikesaisi Hydrogen Energy Co.,Ltd.

SHANDONG PROVINCE, CHINA

Dear Clients: Please read carefully the Operation Manual prior to operation.

Juveniles and those who do not understand the requirements of the manual cannot operate the generators .

Operation Manual for QL Series Hydrogen Generators

1. General Description

The data and operating requirements stipulated in this Operation Manual are applicable to all the series hydrogen generators.

This QL series hydrogen generators are advanced patented products, which are light, highly effective, energy-saving and of environmental protection, producing extremely pure hydrogen through the electrolysis of pure water (without adding alkali).

The SPE electrodes, as the core of the product, are highly active catalytic electrode with nearly zero distance between the electrodes , which is formed by integrating composite catalyst with and ion membrane with high electrolytic efficiency. The other key parts are all produced by use of top-grade engineering plastics dies with superior quality. With perfect electric control system, designs of the generators are advanced with reliable quality, high automaticity, extremely pure generated hydrogen, huge output , the models and specifications of the generators are complete , and the generators are widely used . The small-sized generators are ideal equipment for all kinds of gas chromatographs and thin-film chromatographs, and the large-sized generators can be used in hydrogenation process of chemical industry and pharmaceutical industry, gas reduction protection of electronic industry, purification of semiconducting materials, metal welding, smelting and purification of heavy metals, surface protection of metals, water decomposition and composition in spacecrafts and submarine, and concentration of heavy hydrogen in atomic energy industry, etc. The products can absolutely take the place of hydrogen steel cylinders with safety and convenience in operation.

2. Operational Principles and Technological Process

For the technological process, please refer to Fig.1.

Electrolytic water meeting the requirements (With electrical resistivity $>1\text{M}\Omega/\text{cm}$, and deionized or redistilled water in electronic and analysis industries can be used for this purpose.) , after being put into the anode chamber of electrolytic cell, when power is switched on ,will be decomposed at once at the anode : $2\text{H}_2\text{O} = 4\text{H}^+ + 2\text{O}^{2-}$. The decomposed negative oxyanion (O^{2-}) will immediately release electron to form oxygen (O_2), which will then be discharged from the anode chamber, with some water, into the water tank. The water can be used circularly, and oxygen will be discharged from the small hole of the top cover of the water tank into the atmosphere. The hydrogen proton, in the form of aqua ion ($\text{H}^+ \cdot \text{XH}_2\text{O}$), and under the action of electric field force , through SPE ion membrane, will

arrive in the cathode to absorb electron to form hydrogen, which will then be discharged from the cathode chamber into the gas/water separator, where most of water it brought with from the electrolytic cell will be removed. The hydrogen with little water will be under moisture absorption of the desiccator, with its purity thus reaching 99.997 % or above. When the condensed water in the gas/water separator is accumulated to a certain quantity, it will raise the float and be discharged from the outlet at the bottom of the gas/water separator into the water tank for recycling. The float, after the discharging, will return immediately to its original position, and the water level of the gas/water separator thus remains constant.

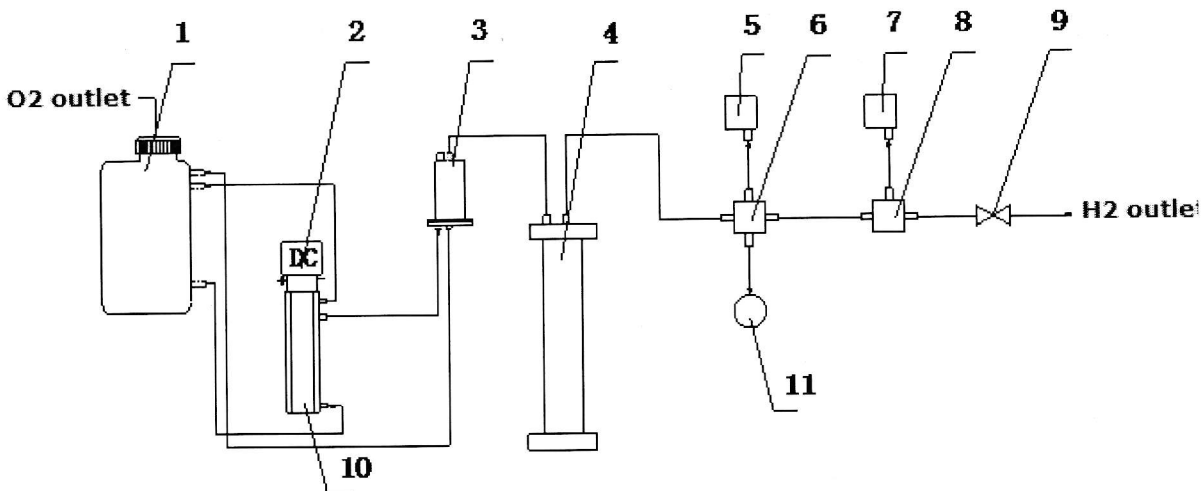

Fig. 1 Technological Process Schematic Diagram

- | | | |
|-----------------------|----------------------------------|------------------------|
| 1. Water Tank | 2. Power Supply for Electrolysis | 3. Gas/Water Separator |
| 4. Desiccator | 5. Pressure Transmitter | 6. Four-way valve |
| 7. Flow controller | 8. Three-way valve | 9. Discharge valve |
| 10. Electrolysis cell | 11. Pressure Gauge | |

3. Electrical Control

For the electrical principles of a complete set of generator, please refer to Fig. 2. The whole electrical system is mainly composed of four parts: a power supply system for electrolysis, main control subcontrol and a display panel. When the power switch SW1 is pressed, the generator will go into operation. In the course of electrolytic process, when air pressure reaches the preset value, the pressure transducer SEN will start to take control to make electrolytic current decreasing along with rising of air pressure, thus enabling output of the generated hydrogen, under the stable pressure, to meet the demand of the consumption automatically.

In addition, the generators, for ensuring normal operation, are equipped with three alarming protection systems.

3.1 Overpressure Alarming

If the output pressure is out of control and rises to 0.46 MPa because of being strongly shaken or something is wrong with its certain parts in the course of operation, the generator will beep four times with an interval and automatically cut off the power supply for electrolysis and stop the electrolysis for realizing the overpressure protection. At that time the front board will show that hydrogen output is zero with pressure alarming light (red) on. End-users should release the pressure and restart up the generator after ensuring that power connection is good with no shaking. If the above-mentioned phenomenon still reoccurs, it can be considered as an failure, end-users should inform the manufacturer for maintenance.

3.2 Failure Alarming .

When the pressure controller is failure or other failure, the Failure alarm will light in the front board, At this point, the user should shut down and contact the manufacture at once.

3.3 Water Accumulated Alarming .

If the instrument is running without pressure (or pressure is “zero”) for long time, the water in gas/water separator will arrive the upper limit, then, the instrument will stop electrolysis and send “beep” alarming ,the alarming light in front board is red. Now, the operator should close the outlet of H2 in the back board, and restart the instrument. (look at 3rd item in “Troubleshooting”)

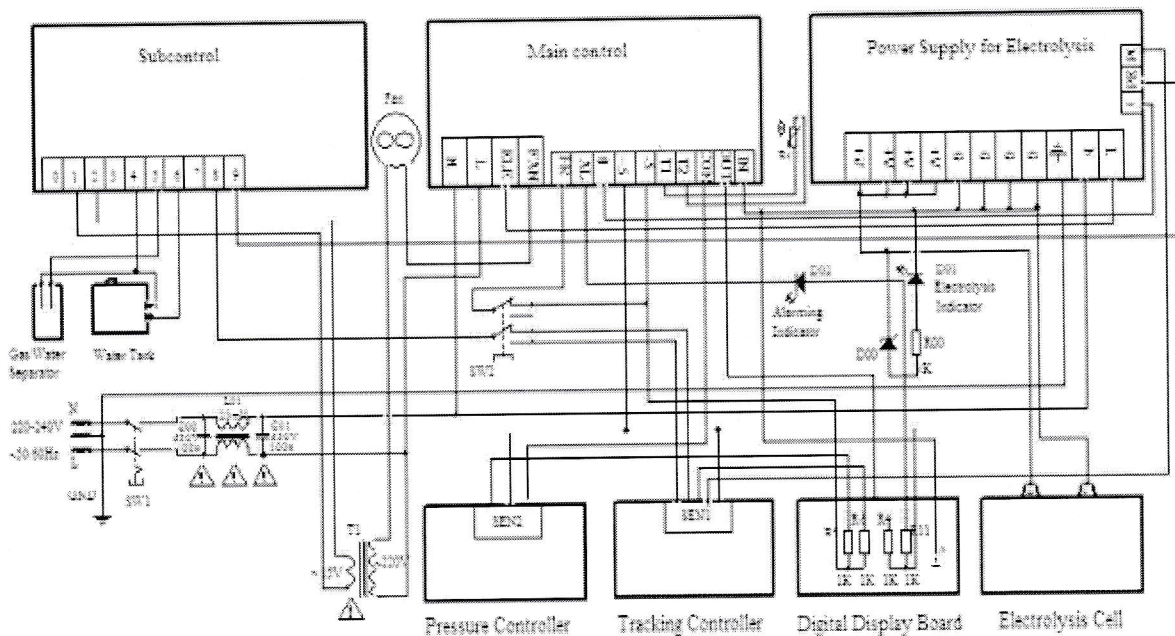

Fig. 2 Control Schematic Diagram

4. Technical Parameters

Parameter	Model	QL-M150	QL-M300	QL-M500
Flow rate	(ml/min)	0-150	0-300	0-500
Output pressure	(MPa)	0-0.4		
H2 Purity	(%)	> 99.999		
Over-pressure Protection	(MPa)	0.46		
Power supply	(V)	110 or 220V ±15%V		50~60Hz
Input Power	(W)	<120	<150	<200
Net Weight	(kg)	<10		
Dimension	(L*W*H) mm	295×200×285		

5. Structure of the Generators

5.1 Contour of Hydrogen Generator

For the contours and dimensions of hydrogen generators, please refer to the front view, side view and rear view in Fig. 3.

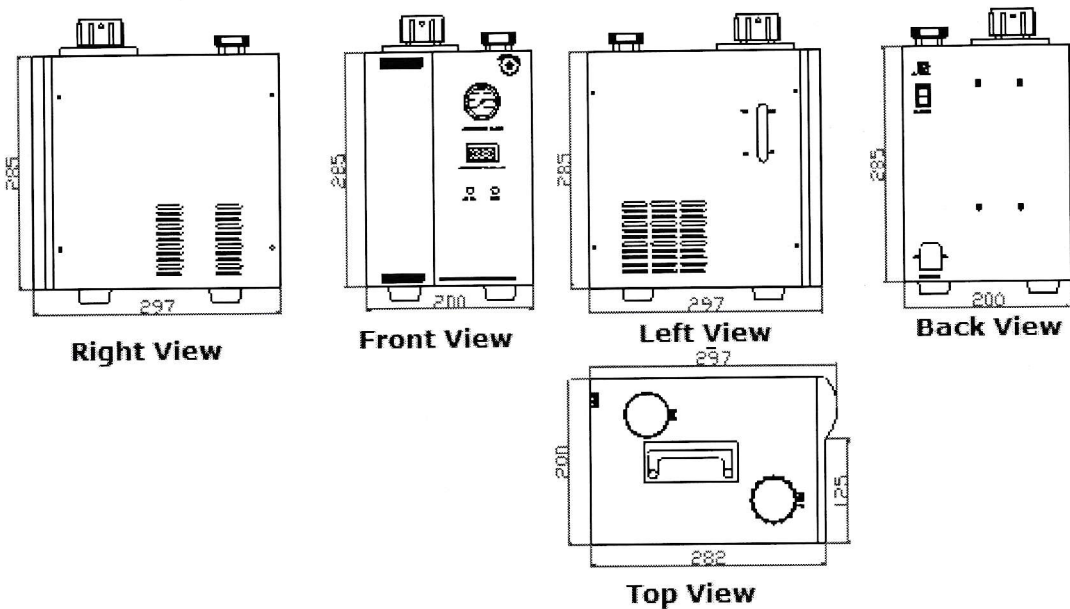

Fig. 3 Contours and Dimensions of Hydrogen Generators

5.2 Internal Structure of Hydrogen Generators

For the internal structure of hydrogen generators, please refer to the following Fig. 4 and 5

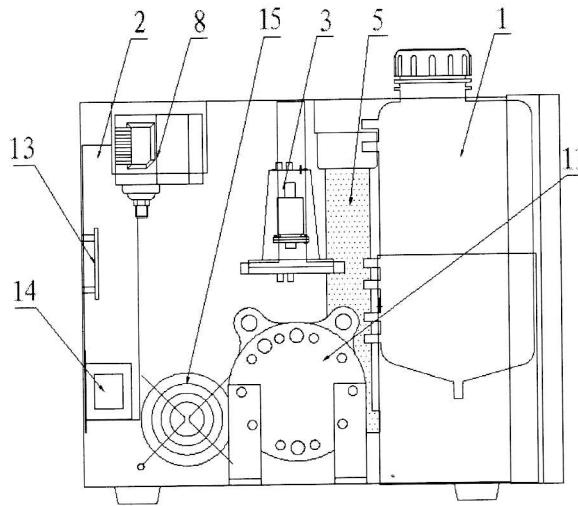
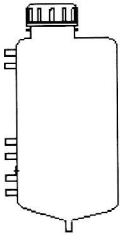
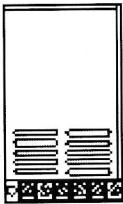
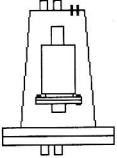
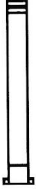
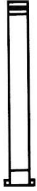
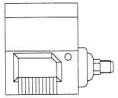
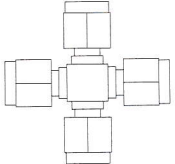
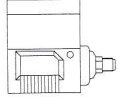
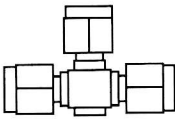

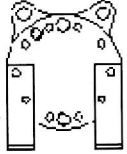

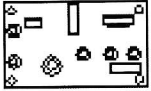
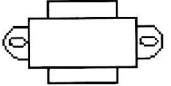
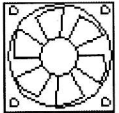
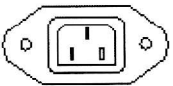
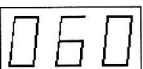



Fig. 4 Left Side View

5.3 Parts list for Hydrogen Generators

No	Description	Profile	No	Description	Profile
1	Water Tank		2	Power Supply for Electrolysis	
3	Gas/water Separator		4	IGrade Desiccator	

OPERATION MANUAL FOR QL HYDROGEN GENERATORS

5	II Grade Desiccator		6	Over pressure Protector	
7	Four-way valve		8	Follow Controller	
9	Three-way Valve		10	Gas Discharge Valve	
11	Electrolysis Cell		12	Pressure Display meter	
13	Control Panel for Drainage		14	Transformer	
15	Electric Fan		16	Socket for Power Supply	
17	Flow rate Display Screen		18	Power Switch	

5.4 Key Parts of Hydrogen Generators

5.4.1 Electrolysis Cell

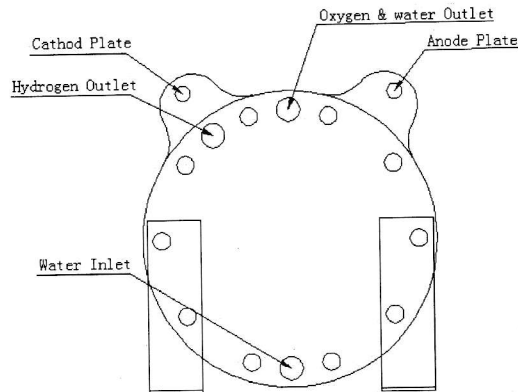

(1) Replace Way

① Take away the sealing film in water inlet and H₂ & water outlet. Let the cell erected, then little water will flow out.

② Fix the frame of the cell with M5 bolts in right place.

③ Connect the water inlet and water tank outlet with $\Phi 6 \times 9$ Silicone pipe. At the same time, connect oxygen & water outlet and water tank cycle water inlet with another silicone pipe.

④ Connect the power positive line to the positive plate of cell, Negative line is connected to negative plate. Fix and tighten with M6 bolts.

⑤ Connect H₂ outlet and H₂ & water Separator inlet. Must tighten the nuts in the joints, in cast of leakage.

(2) Common Faults

① The electrolysis efficiency decline, the flow display is less than 50ml/min, It can be judged as electrolyzer failure

② The cell is made up with one or several until cells. The until cell is separated into Anode chamber and Cathode chamber by SPE membrane. There are oxygen gas and water in Anode chamber, and hydrogen gas and water in cathode chamber. If there is holes in SPE membrane, The hydrogen gas will penetrate into Anode chamber, then the output pressure cannot reach the set pressure. There will be little or no gas pocket in gas/water separator. And there are more gas pocket in the gas/water separator outlet. It can be judged as cell Reverse osmosis failure. The cell should be replaced.

(3) Considerations

- ① Must use deionized or redistilled water with electrical resistivity $>1M\Omega/cm$, If the substandard water will damage the cell.
- ② Must connect the power line right.
- ③ There must be water in the cell in any time. If you donot use that for long time, it should be put some water in the cell.

5.4.2 Gas/ Water Separator

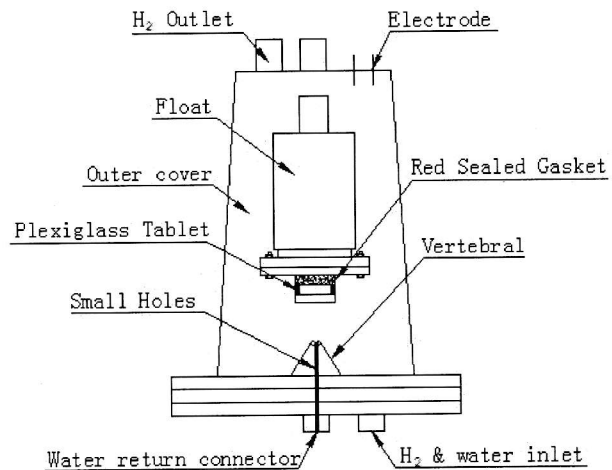

(1) Gas/ water separator function

The H₂ & water from the cell enter into gas/water separator through gas/water separator H₂ & water inlet. When the condensate water in gas/water separator is accumulated to certain amount, (about at 1/2 of outer cover), the float will float. The red sealed gasket will be divorced from the top of vertebral, the condensate water under the Hydrogen gas pressure, will enter into the water tank through the small holes of the vertebral. After dewatering, the float will diaplasis at once . Reciprocate like this. The water level in the gas/water separator is kept constant, it can separate the water and gas.

(2) Leakage Faults

The hydrogen gas will be leaked because of the bad seal between red sealed gasket and the top of vertebral, it will appear that the Hydrogen gas output pressure cannot reach the set value or the pressure is not under stable and there is no or little condensate water in gas/water separator, the gas pocket will flow quickly in the return water inlet. It can be judged as gas/water separator faults. The reason of bad seal is followed:

-
- ① The surface of red sealed gasket is uneven because of long time using.
 - ② It appears loose in the plexiglass tablet, it can cause the sealed gasket float.
 - ③ The read sealed gaske expand because of touching the water for long time, it can cause that there will be sphere between plexiglass tablet.
 - ④ There is skin needling in the top of vertebral;
 - ⑤ All of above reason can cause the hydrogen gas leakage in gas/water separator, please check one by one.
- (3) Water accumulated alarm fault
- ① If the small holes of gas/water separator is block. It can cause the gas/water separator cannot let the water out.
 - ② Replace the gas/water separator, must ensure that the float can float up and down. If the float is blocked, it can also block the small holes.

6. Operational Requirements

6.1 This hydrogen generator cannot be used in sealed room .

6.2 Requirements for operational environments and conditions of the generators :

- a. Temperature : 4°C– 40°C ;
- b. Humidity : <85% ;
- c. Power supply : 220v--240V~50-60Hz or 99-121v~50-60Hz;
- d. The generators should be put horizontally near hydrogen-applied instruments with their front boards facing operators for the convenience of operation;
- e. There should be no obvious shaking and striking;
- f. There should be no direct sunshine and open fire;
- g. There should be no big dust , conducting particles , acid , alkali , and other corrosive gases ;
- h. Ventilation should be good ;
- i. Ground connection of power supply should be good . 

6.3 The water tank of a generator should at first be filled with deionized or redistilled water and then you should wait for five minutes prior to startup.

6.4 Requirements on pressure rising and how to deal with hydrogen produced when the set pressure is reached without connecting hydrogen-applied equipment .

(1) During operation of the generators, operators are not allowed to look down at the sealed top caps of the two-stage desiccators from above in order to prevent eyes and faces from injuring .

(2) The generators cannot be operated when the output pressure is zero, and the minimum

pressure for operation is 0.02 MPa. After start-up the pressure should be raised before it is too long, or it will lead to internal ponding without normal draining of gas/water separator, making the water level reach the maximum limit of alarming, resulting in stopping electrolysis. When output of hydrogen reaches the maximum value, time of the operation with zero of output pressure should not be over 10 minutes. (Generally speaking , after the generators are delivered some internal resistance will be produced since the generators have been equipped with two-stage desiccators and brass pipelines connecting hydrogen output flow direction , and generally speaking , the internal resistance can reach the required limit of the minimum pressure.)

(3) After start-up a generator is not allowed to be operated for a long time when the set pressure is reached without connecting hydrogen-applied equipment, or it will damage the core components of electrolytic cell.

6.5 The pressure of a hydrogen generator should be released to zero after it is shut down .

The pressure can be released by loosening the nut of venting valve in front of the hydrogen outlet on the backplate. The valve should be sealed again after the pressure is released .

6.6 Requirements for Water Quality

As hard ions in unqualified water may cause sediment to block pores of electrodes, thus resulting in scrapping of the electrodes, the electrical resistivity of water (deionized or redistilled water) in electrolysis should not be less than 1MΩ/cm. All end-users should keep it in mind, otherwise they should be responsible for all consequences.

6.7 Water Level Requirements for Water Tank

(1) The water level should be over two thirds of the volume of the water tank (volume of water tank is 3.2 L).

(2) Water should not be poured into the water tank violently and quickly to prevent water from spilling out of the nylon overflow , under which there is an O ring sealing the housing of the generator to prevent water from entering the generator to damage the electric components .

6.8 Requirements for Changing Water and Cleaning Water Tank

The water tank should be kept clean. Even the water is qualified at first, it will breed microorganisms and become turbid when it is used for a long time, influencing output of the hydrogen and the service life of electrolysis cell. The water tank, therefore, should be emptied through the drain pipe every two or three months, and then washed several times (fill the tank with a small quantity of new water and shake the generator lightly several times in every direction) until discharged water becomes transparent without cottony things.

The drain pipe of water tank is attached to the backplate of the generator and can be freely taken off and put in.

The small hole on the top cover of the water tank is used as oxygen discharging port, therefore do not block it , and the top cover of the tank should not be changed at random.

6.9 During transportation of the generators, the water tanks should not store water so as to prevent the water from spilling out to cause damages of the electrical components.

6.10 The electrolytic cells should not be short of water .

6.11 Requirements and Methods for Replacing Desiccant

The hydrogen generators manufactured by our company feature less internal resistance, high electrolytic efficiency, and extremely small consumption for transforming electric energy to heat energy, therefore the service life of desiccant (silica gel or molecular sieve) is the longest among all hydrogen generators in the market up to now. If the phenomena contrary to the above-mentioned occur or the color of desiccant changes in a large proportion, it is possible that the generator has been in operation for a long time at full capacity and with a huge output . When you correct the above-mentioned improper operations and the color of desiccant still changes very fast, the manufacturer should be informed for maintenance .

6.11.1 Introduction on Replacing Desiccant

The desiccator is located inside the right plate (facing the front board look backward it is on the right side) equipped with a desiccant view port. The drying procedure is divided into two steps.Two desiccant cartridges with blue silica gel is the first drying and one with incarnadine molecular sieve as the secondary drying respectively.

The top caps covering the three desiccant cartridges protrude outside the top cover of the generator, and arranged in a single row, with the same way for their replacements.

6.11.2 Requirements for replacing desiccant

(1) The desiccant should not be replaced during the operation of the generators to prevent high-pressure hydrogen from leaking and injuring people .

(2) Before desiccant is replaced , a generator must be shut down and the pressure must be released prior to unscrewing and opening top cap of the purifier .

(3) The desiccant (discolored silica gel or molecular sieve) will lose effectiveness after water uptake to saturation, and should thus be replaced on time . When the height of discolored silica gel is over half of that of the view port, it must be replaced ! Or the water content in hydrogen will be more than the standard , influencing the purity of generated hydrogen . The molecular sieve for the secondary drying might be replaced once half a year or a year provided that the silica gel for the first drying is replaced in time

(4) The generator, after desiccant replacement, should be in idle operation for several minutes to wait for air to be emptied from the desiccant cartridges ,and hydrogen can only be used when purity of generated hydrogen reaches the standards .

6.1.3. Methods for Desiccant Replacements

Desiccant Regeneration

- ① The silica gel should be baked under the temperature between 120 and 140 °C until its color changes into blue completely .
- ② The molecular sieve should be baked under the temperature between 150 and 180 °C for 2 hours.
- ③ The above-mentioned desiccant should be packed for use when it is dried and its temperature decreases to below 50° C , and it will scald skin if its temperature is too high . Too high temperature will scale the containers or skin of operators .

6.12 A generator must be shut down before it is repaired . During operation of a generator , do not disassemble housings and other components of the generator in order to avoid an electric shock .

6.13 A generator must be shut down by power cord disconnect with power source before cartridge fuse is replaced . Model of cartridge fuse used in QL-M150, QL-M300,QL-M500 is F8AL250V, please do not make mistakes in using the cartridge fuse so as to avoid fires .

7. Acceptance Check

7.1 Unpacking for the acceptance check

Please check the generator are in good condition and make sure attached **accessories are in ready according to picking list. If the generator is damaged during transportation, please immediately contact with transport company and manufacturer for solution.**

7.2 Operation for the acceptance check

7.2.1 The operational environment and conditions of the generators should meet the requirements stipulated in 6.2.

7.3.2 Open the top cap of the water tank on surface of the generator and remove the plug . Fill water tank with deionized or redistilled water and water level in the tank should be between the Min. water limit line and Max. water limit line and finally screw the top cap.

The plug is used to prevent residual water from leakage during transportation. Please keep this plug in safty place in order to use it next time.

Since there is increasing oxygen gas produced through electrolyzation in water tank and the plug has strong good seal function. If the plug is not removed during generator works, the air pressure will be constantly increased in water tank and finally it will make water tank burst. Thus please remove the plug before generator starts up.

Operator should pay attention to this point.

There is a hole (3 mm in diameter) at top cap. It is used to release oxygen gas. Please keep this hole unblocked.

Caution: Before the generator is started up, please fill water at first and make sure there is adequate water in electrolytic cell.

Caution : The generators must be filled with water prior and then start up ! Water must be guaranteed for electrolytic cells !

7.3.3 Connect source of power supply and the generator by using power cord along with the delivered generator , and insert the end of power cord in the socket (Serial No. is 35) on the back panel of the generator , and then insert the plug of power cord in the socket of the power supply board . Ground connection of power supply must be good according to the requirements of 6.3 of the operation manual. After connecting the power cord, turn on the switch of power supply on the front panel. Both the power supply indicator and the electrolysis indicator (green) will be on, and the number indicating the output of hydrogen will be increasing all the way to the maximum output of the generator.

7.3.4 When the nut for hydrogen outlet of the generator is sealed (or screwed) securely, output pressure will rise, and when the pressure reaches the preset value, the pressure control system will take control to make the electrolytic current reduce to zero, and the number indicating output flow rate will show falling to zero. The number indicating output flow rate will show returning to the maximum of generated hydrogen when the above-mentioned nut is unscrewed, which indicates the generator is in normal operation. After the acceptance check is completed, the generator can be operated in accordance to the Operational Manual.

7.3.5 Connecting hydrogen-applied equipment

After acceptance check, at first shut down a generator when you are prepared to use it. Produce the pipe (a brass coil pipe with outer diameter of 3 mm , wall thickness of 0.5 mm and length of 1,500 mm) connecting hydrogen-applied equipment from an accessories bag along with the generator . When a generator is delivered , the two ends of the pipe have been equipped respectively with an international standard threaded nut of M8×1 and three O-rings for sealing . Distance between each end of O-rings and that end of the brass pipe is 6-8mm . The one end will connect outlet port of a generator , and another end will connect a set of hydrogen-applied equipment in the same way . If nozzles of hydrogen equipment are measured in the British system , for example , chromatographs made by Shimadzu of Japan , Agilent and Varian of USA , whose sizes of nozzles are measured in the British system , We can accessorize relevant nozzles according to different requirements of our customers and will mark out on the accessories bags of nozzles .

Insert the two ends of a connecting pipe into the relevant nozzles , and use a spanner delivered along with the generator to seal the nuts and nozzles in clockwise sense . Do not overexert yourself in sealing the nuts prevent the O-rings losing elasticity , resulting in influencing the sealing effect .

After hydrogen-applied equipment is connected , use soap suds to check the sealing for leakage . If bubbles occur , the assemble should be readjusted until no leakage is found . The same method should be used for checking leakage in sealing nuts of the other parts and components .

8. Troubleshooting

Warning: The qualified person can go into the maintenance and repair of the generator only. Draw the power cord plug off from the power supply socket before any working of maintenance and repair, to avoid electric shock.

Breakdown	Causes	Guide for maintenance
<p>1. When the power switch is turned on, the power indicator light will not be on and the generator will not be in operation.</p>	<p>1. The power plug is in poor connection. 2. Blown fuse. 3. Power switch is damaged.</p>	<p>1. Recheck the plug and make it in good connection. 2. Take out and replace the damaged safety wire in the fuse. The replaced safety wire must be up to the type of the original safety wire. Do not change type of safety wire at will. 3. Repair or make replacement.</p>
<p>2. When the electrolysis indicator light is on with the maximum output generated, the pressure does not rise.</p>	<p>1. Leak in the pipe system. of hydrogen. 2. Poor sealing condition at the float of the gas/water separator with water outlet. 3. Sharply increasing output from the oxygen outlet means electrolysis cell has been damaged.</p>	<p>1. Use leak-hunting liquid to check sealing of all nuts, screw securely the fittings at the leaks. 2. Repair or replace the fittings. 3. Shut down the generator at once !The electrolysis cell, if damaged, must be returned to the manufacturer for replacement. Do not disassemble it by yourself, or you will be responsible for all the consequences arising thereby.</p>
<p>3. Beep four times with an interval, alarming light is red.</p>	<p>Disconnected in the socket, and the contact is faulty. When power is turned off ,it is switched on immediately. The generator has been shaken. Mistakes made in selecting pressure.</p>	<p>1. Check, make current and restart the generator. 2. Wait for 6 minutes after shutting down the generator prior to restart-up. 3. Remove shaking and release the pressure prior to restart-up. 4. Restart up after releasing the pressure. If the system still beeps after doing according to the above-mentioned, inform the manufacturer for maintenance, do not disassemble it by yourself.</p>

Breakdown	Causes	Guide for maintenance
<p>5. If water is found to drain out of basal crack of the generator (The problem is rarely seen).</p>	<p>1. Silicon rubber soft pipe and nylon ribbons are aging. The sealing O-rings between the metallic pipe and nuts are aging.</p> <p>2. The sealing pad of electrolytic cell is aging.</p>	<p>1. Shut down the generator and release the pressure of hydrogen. After draining off water from the draining pipe on the back board, it will be ok to replace the same accessories. (Water used by the generators is not corrosive , so rub out the spilled water in the housing and use an air blower to blow it dry before restarting up the generator.</p> <p>2. The manufacturer will be responsible for repairing breakdown of electrolytic cells or making replacements.</p>
<p>4. Beep once every six seconds approximately.</p>	<p>Water tank is short of water.</p> <p>Ponding in the gas/water separator.</p>	<p>1. Add some water to the water tank.</p> <p>2. The generator has been operated for a long time with zero pressure or there are leaks in the pipe system .If the system gives an alarm when the pressure is over 0.012 MPa, it is a breakdown of the generators, inform the manufacturer for maintenance.</p>

9. After-sales Service

The warranty period of the generators is one year, and the maintenance will be lifelong . Maintenance and replacement of parts within the warranty period will be done free of charge, and beyond the warranty period, they will be done with only cost of the raw materials charged.

If the following occurs , the maintenance will not be done free of charge:

- a. users do not operate the generators according to the operational manual;
- b. users disassemble parts by themselves , which are forbidden by the manufacturer to be disassembled.

Our company is able to undertake maintenance of all hydrogen generators with the SPE technology at home or abroad.

Packing List

No.	Name	Specifications	Quantity	
1	Hydrogen Generator		1	
2	Power-line		1	
3	Operation Manual		1	
4.	Bags For parts	Pipe for connecting hydrogen-using equipment	ϕ 3, M8 nut	1
5		Safety Wire	6A	2
6		Sealing ring (gasket)		some
7		Changing connector for matching with Agilent GC		1
8		Metal ferrule	ϕ 3	1

Warranty Card

Name of End-user

Model	QL-M150	Serial No.		Date of Check	Dec. 2021
Seller	SAIKESAISI	Invoice No.	IP/160729D	Date of Manufacture	Dec. 2021

Record on Maintenance

Date	Item to be repaired	Parts Replacement Record	Signature of Repairer	Signature of End-user

Statement on Maintenance

1. End-user is kindly required to fill in all items of the warranty card.
2. The warranty period for the generators is one year (starting from the date of manufacture).
During the period, maintenance will be carried out free of charge..
3. Maintenance will be done during the lifetime of the generators, and, beyond the warranty period, it will be carried out ,only charging the cost arising thereby.
4. Such cases will not be covered by the warranty as for failing to operate according to the Operation Manual of the generators or man-made damages