



SyringePump.com

ANA-BOX™ 1.0

Analog Pump Interface

with external switch control

Part# ADPT-ANABOX-1.0

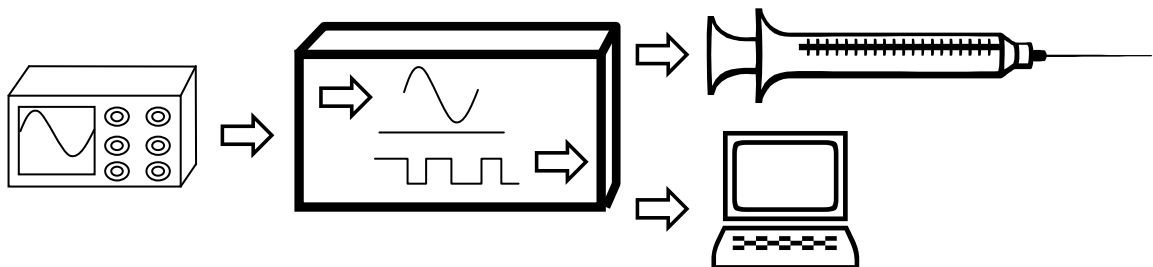

“WHAT’S YOUR APPLICATION?”™



WARNING
NOT FOR
CLINICAL
USE ON HUMANS

Table of Contents

1.	GENERAL INFORMATION	1
1.1.	WARNINGS AND CAUTIONS	1
1.2.	DISCLAIMER	1
1.3.	WARRANTY	2
1.4.	PACKING LIST	2
2.	OVERVIEW	2
3.	SYSTEM SETUP	3
4.	USER INTERFACE	4
4.1.	RUN SWITCH CONTROL	4
4.2.	LED	5
5.	OPERATION	5
6.	PUMP PARAMETER SETUP FOR ANA-BOX™ OPERATION.....	7
6.1.	MODE 1: RAMP WITH VOLTAGE	9
6.2.	MODE 2: START PUMP AT TRIGGER VOLTAGE	10
6.3.	MODE 3: STOP PUMP AT TRIGGER VOLTAGE.....	10
6.4.	MODE 4: START PUMP WITHIN VOLTAGE RANGE.....	11
6.5.	MODE 5: STOP PUMP WITHIN VOLTAGE RANGE	11
6.6.	MODE 6: VOLTAGE HOLD NEGATIVE INCREMENT.....	12
6.7.	MODE 7: VOLTAGE HOLD POSITIVE INCREMENT.....	13
6.8.	MODE 8: TRIGGER EVENTS AT 1 VOLTAGE LEVEL	14
6.9.	MODE 9: TRIGGER EVENTS AT 2 VOLTAGE LEVELS	15
6.10.	MODE 10: JOYSTICK SPEED AND DIRECTION CONTROL	16
7.	SUB-MODES OF OPERATION	16
7.1.	ALLOW “PUMP CONTROL” DISABLE SUB-MODE 0.1	16
7.2.	INFUSE ONLY “PUMP CONTROL” SUB-MODE 0.2	17
7.3.	DISABLE BEEP FOR PARAMETER CONFIRMATION SUB-MODE 0.01	17
7.4.	DISABLE VOLTAGE LEVEL SHIFTS SUB-MODE 0.02.....	17
8.	COMPUTER DATA LOGGING.....	18
9.	SPECIAL APPLICATIONS	20
9.1.	PROPORTIONAL PUMPING: DUAL PUMP CONSTANT FLOW RATE	20
9.2.	DISABLE “PUMP CONTROL” EXAMPLE.....	20
10.	TECHNICAL SPECIFICATIONS.....	22
10.1.	RJ-11 CONNECTOR WIRING	22
10.2.	RATINGS AND LIMITS	22

* The Ana-Box™ is optimized to work with the NE-1000 pump. Please enquire for use with a different pump.

1. General Information

Thank you for purchasing the Ana-Box™. With the Ana-Box™ and a programmable pump, you will be able to create an intricate pumping system with analog signal control.

Please familiarize yourself with the Ana-Box™ operation by reading this user's manual. For future reference, record the serial number, located on the bottom of the unit, and the date of purchase.

New Era Pump Systems Inc., located in Farmingdale, NY USA, can be contacted at:

Phone: (631) 249-1392

FAX: (707) 248-2089

Email: INFO@SYRINGEPUMP.COM

www.SyringePump.com

This Operating Manual, and the Ana-Box™ hardware, electronics and firmware are copyrighted.

Copyright 2004-2012, all rights reserved.

1.1. Warnings and Cautions

- ⚠ Read the user manual
- ⚠ No user serviceable parts are inside.
- ⚠ Disconnect power when connecting or disconnecting cables.
- ⚠ Do not immerse the unit in liquid
- ⚠ Install on a stable surface.
- ⚠ The pumping system can automatically start whenever the system is powered.
- ⚠ Prevent liquids from entering any openings in the box or the pump.
- ⚠ Use only with the specified power supply connected to a power source as specified on the power supply label.
- ⚠ Do not push objects of any kind into the unit's openings, except for appropriate cables and connectors.
- ⚠ If the unit becomes damaged, do not use unless certified safe by a qualified technician. Damage includes, but is not excluded to, frayed cords and deterioration in performance.
- ⚠ Discharge static from control cables before connecting by touching the cable to ground.
- ⚠ Before touching the pump, discharge static by touching ground.

1.2. Disclaimer

New Era Pump Systems Inc. makes no representations or warranties, expressed, statutory or implied, regarding the fitness or merchantability of this product for any particular purpose. Further, New Era Pump Systems Inc. is not liable for any damages, including but not limited to, lost profits, lost savings, or other incidental or consequential damages arising from ownership or use of this product, or for any delay in the performance of its obligations under the warranty due to causes beyond its control. New Era Pump Systems Inc. also reserves the right to make any improvements or modifications to the product described in this manual at any time, without notice of these changes.

New Era Pump Systems Inc. products are not designed, intended, or authorized for use in applications or as system components intended to support or sustain human life, as a clinical medical device for humans, or for any application in which the failure of the product could create a situation where personal injury or death may occur.

All brand and product names used in this manual are the trademarks of their respective owners.

1.3. Warranty

New Era Pump Systems Inc. warrants this product and accessories for a period of two years, parts and labor, from the date of purchase. The repaired unit will be covered for the period of the remainder of the original warranty or 90 days, whichever is greater.

A return authorization number must be obtained from New Era Pump Systems Inc. before returning a unit for repair. Warranty covered repairs will not be performed without a return authorization number. At the option of New Era Pump Systems Inc., a defective unit will be either repaired or replaced.

This warranty does not cover damage by any cause including, but not limited to, any malfunction, defect or failure caused by or resulting from unauthorized service or parts, improper maintenance, operation contrary to furnished instructions, shipping or transit accidents, modifications or repair by the user, harsh environments, misuse, neglect, abuse, accident, incorrect line voltage, fire, flood, other natural disasters, or normal wear and tear. Changes or modifications not approved by New Era Pump Systems Inc. could void the warranty.

The foregoing is in lieu of all other expressed warranties and New Era Pump Systems Inc. does not assume or authorize any party to assume for it any other obligation or liability.

1.4. Packing List

Included with the Ana-Box™ are the following items:



- This Operating Manual
- RS-232 Pump interface cable

2. Overview

The Ana-Box™ is a peripheral device that adds an analog control input to a New Era Pump Systems Inc. pump.

The Ana-Box™ accepts a positive voltage input that is used to control the pump. Depending on the mode and setup parameters, control commands are sent to the pump via the RS-232 computer interface. The Ana-Box™ reads all of its setup information from the attached pump.

The analog control input voltage range is 0 to 12V. The Ana-Box™ will automatically adjust for higher precision at lower input voltages, to accommodate for applications that do not require the full 0 to 12V operating range. Thus, you will have similar precision if your input is 0 to 3V as you will have if your input is 0 to 12V.

Operating voltage: 0V to 12V

Absolute maximum input voltage: 24Volts

In addition, the Ana-Box™ has a computer data logger output. This output sends periodic status information via a RS-232 interface. This output can be read by a computer and saved in a log file, or the output can be sent directly to a printer.

3. System Setup

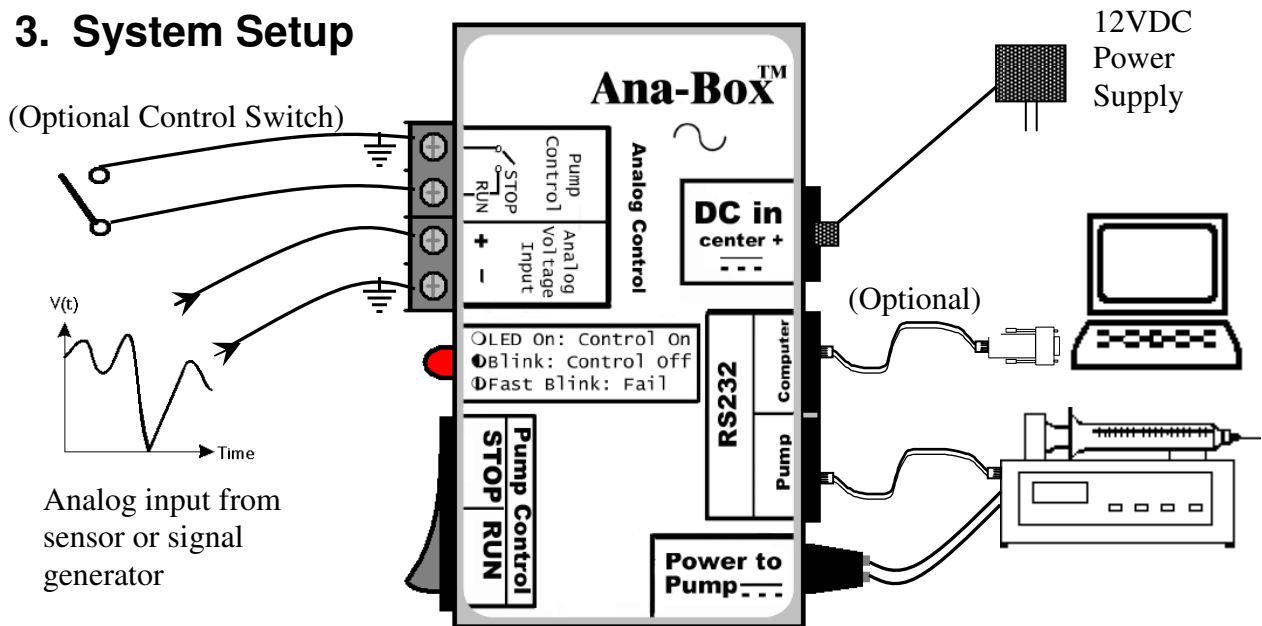

Pump Setup

If the pump's factory default communication setup was never changed, then you can skip this step.

Using the pump's setup (Press and hold the 'Setup' key to enter setup), set the address to '0' and the baud rate to 19,200.

Network address: 0 (Displayed as Ad:00)

Baud rate: 19,200 (Displayed as 1920)

Analog Input

Using a small screwdriver, attach the analog lines to the "Analog Voltage Input" connector, observing proper polarity. Attach the signal wire to the connector labeled (+) (voltage input: 0 to 12 V), and the ground wire to the connector labeled (-) (internally connected to Ground).

Attaching the Ana-Box™ to the Pump

- Set the Ana-Box™ "Pump Control" switch to "STOP".
- Attach one end of the modular cable (telephone style cable) to the "Pump" connector on the Ana-Box™.
- Attach the other end of the cable to the "To Computer" connector on the rear of the pump.
- Plug the power cable from the Ana-Box™ into the DC power input jack on the back of the pump *(single syringe pump standard power models only).
- Plug the wall adapter power supply for the pump *(single syringe pump standard power models only) into the "DC Power Supply" input jack on the Ana-Box™.
- Turn on the power switch on the pump.

(Optional) Attaching the Ana-Box™ to a Computer for Data Logging

Accessory cable CBL-PC-PUMP-7 is required.

- Attach one end of the modular cable (telephone cable) to the "Computer" connector on the Ana-Box™.
- Attach the other end of the modular cable to the 9 pin adapter connector.
- Attach the 9 pin adapter connector to the RS-232 serial communications port on the computer.
- To attach to a USB port, add the USB to RS-232 converter cable.
Part#: CBL-USB232.

(Optional) External Start/Stop Control

Allows an external logic signal, or switch, to Start/Stop the Ana-Box™.

- The external "Pump Control" provides the same functionality as the "Pump Control" switch on the Ana-Box™.
- Set the "Pump Control" switch to "STOP". Connect your external switch to the external "Pump Control" connector using a small screwdriver, or external signal to the Run connector.

4. User Interface

The Ana-Box™ uses the pump's user interface to set all operational parameters. A triangle will appear in the upper left corner of the pump's LCD display when communications is established with the Ana-Box™.

4.1. Run Switch Control

RUN status of either the "Pump Control" Switch or the External Pump Control will start the Ana-Box control.

"Pump Control" Switch

STOP The Ana-Box™ is not controlling the pump.

When switching to "STOP", the pump will be stopped if it was pumping.

RUN The Ana-Box™ starts pump control.

The mode and setup parameters are read from the pump and control begins according to the setup. The pump will beep twice if the setup is valid.

NOTE: The pump may immediately start to pump, depending on the mode and setup parameters.

"Pump Control" using External Signal or Switch

STOP Logic High (1): Stop pump control
Opening switch will stop the pump. (Internal pull up).

RUN Logic Low (0): Start pump control
Closing switch to Ground will start the pump
See diagram in Sec: "3, System Setup".

4.2. LED

The LED indicates the operational state of the Ana-Box™ as follows:

- On Actively controlling the pump according to the setup parameters
- ◐ Slow blink Stopped. Pump is not being controlled.
- ▨ Fast blink Analog input is over voltage.
- ◑ Partial blink Diagnostics mode.

5. Operation

All setup information is stored on the pump and read from the pump when “RUN” is selected on the "Pump Control" switch. Before selecting “RUN”, the pump should be setup with the appropriate syringe diameter.

- If setup information is found on the pump and it is valid, normal pump control mode is entered and the pump will beep twice (if enabled).
- If an error is found in the setup information, the pump will not beep, and pump control mode will not be entered.
- If no setup information is found on the pump, then the default "Plug-n-Play" pump control mode is entered.
- If communications cannot be established with the pump, "Diagnostics Mode" will be entered.

Starting Pump Control Mode

After selecting “RUN” on the "Pump Control" switch, the Ana-Box™ reads the setup information from the attached pump. If the setup information is valid, the pump will beep twice (if enabled). If the setup information is not valid, the pump will beep continuously. If communications cannot be established with the pump, the Ana-Box™ enters Diagnostics mode. Selecting “RUN” may require flipping the switch to “STOP”, then to “RUN”.

The Ana-Box™ allows for an external switch control. Set the “Pump Control” switch to the “STOP” position, then the pump can be controlled using an external control switch.

Re-Starting Pump Control Mode

While “RUN” is selected on the "Pump Control" switch, if the pump stops due to an alarm condition, pressing the 'Stop' button on the pump, or the end of a dispense program, pump control will also be stopped, indicated by the LED blinking.

If the pump is restarted, such as by pressing the ‘Start’ button on the pump, the Ana-Box™ will detect the pump restart and resume Pump Control mode, indicated by a solid LED on the Ana-Box™. NOTE: when pump control is restarted, the setup is not

re-read from the pump. The Pump Control will continue with the previously read mode and parameters.

Pump control can also be restarted by moving the "Pump Control" switch to "STOP", then back to "RUN". In this situation, the pump mode and parameters will be re-read unless the pump operation was paused, indicated by a blinking "Run" LED on the pump.

If the pump's power is cycled off and on, "Pump Control" cannot be restarted by starting the pump. "Pump Control" must be restarted by cycling the "Pump Control" switch.

Power Failure Mode Re-Start

On power up, the Ana-Box™ will automatically start controlling the pump under the following conditions:

- Power Failure mode is set on the pump
- The control switch is set to "RUN"

Diagnostics Mode

When "RUN" is selected on the "Pump Control" switch and communications cannot be established with the pump, "Diagnostics Mode" is entered. "Diagnostics Mode" is indicated by a slow blinking of the LED. In this mode, the Ana-Box™ will transmit voltage data to the computer logging output. Voltage data will be transmitted once per second. Voltage data will be in the format of "nnnn", plus a decimal point.

If you forget to turn on the pump's power switch when selecting "RUN", "Diagnostics Mode" will be entered. In this situation, move the switch back to "STOP", turn on the pump's power switch, then select "RUN" again.

Each time that the Ana-Box's switch is moved to "STOP" then back to "RUN", an attempt is made to establish communications with an attached pump. If communications is established, "Diagnostic Mode" is exited, and normal pump control operational mode is entered.

"Plug-and-Play" Mode

If the pump has not been setup with Ana-Box™ operating parameters, the Ana-Box™ will enter its default operating mode. The default mode is 'Ramp with Voltage' (Mode 1). In this mode, the minimum and maximum voltage will correspond to the minimum and maximum pumping rates.

0 V => 0.0 pumping rate
12 V => Maximum pumping rate

The maximum pumping rate will vary according to the current diameter entered for the syringe and the model of the pump.

Over Voltage

If the input voltage exceeds the maximum operational voltage (12 V), the LED will blink fast. The voltage will be interpreted as the maximum operational voltage for pumping rate control purposes.

6. Pump Parameter Setup for Ana-Box™ Operation

Orientation

The Ana-Box™ reads all of its setup information from the attached pump. The attached pump's Pumping Program phases are used as memory location addresses. Each setup parameter is stored at a specific phase number. Additionally, each setup parameter is stored at the specific phase location as if it were a pumping rate, with the program function for the phase set to 'RATE'.

For example, to set mode 5, set Program Phase 30 to 'RATE' function, then store 5.0 mL/hr as the phase's pumping rate.

NOTE: When parameters R_1 and R_2 are used (for indicating minimum and maximum flow rates), the rate units for both parameters must be the same. The rate units specified with the Mode or voltage settings are ignored.

Parameter locations not relevant to the specified Operating Mode will be ignored.

Pumping Program Phases Used for Setup

Phase #	Description	
30	Operating Mode	
	Parameters	Parameters
31	V_1 : Voltage trigger 1	R_1 : Rate @ 0 V
32	V_2 : Voltage trigger 2	R_2 : Rate @ Vmax
33	Vmax : Maximum voltage	ΔR : Rate incr/decrement
34	Reserved	
35	E_1 : Trigger 1 Pump Event Phase	
36	E_2 : Trigger 2 Pump Event Phase	
37	E_3 : Trigger 3 Pump Event Phase	

Operational Modes and Parameters Summary

Mode	Description		Parameters
1	$\Delta V = +/-\Delta R$	Ramp with voltage	R_1, R_2, V_{max}
2	Start $\geq V_1 >$ Stop	Start pump at voltage trigger	V_1
3	Stop $\geq V_1 >$ Start	Stop pump at Voltage trigger	V_1
4	Stop $< V_1 \leq$ Start $\leq V_2 <$ Stop	Start pump within voltage range	V_1, V_2
5	Start $< V_1 \leq$ Stop $\leq V_2 <$ Start	Stop pump within voltage range	V_1, V_2
6	$\Delta R < V_1 \leq$ Steady $R \leq V_2 < -\Delta R$	Voltage hold, negative increment	$V_1, V_2, \Delta R$
7	$-\Delta R < V_1 \leq$ Steady $R \leq V_2 < \Delta R$	Voltage hold, positive increment	$V_1, V_2, \Delta R$
8	$E_1 < V_1 \leq E_2$	Trigger pump events at Voltage	V_1, E_1, E_2
9	$E_1 < V_1 \leq E_2 < V_2 \leq E_3$	Trigger pump events at Voltages	V_1, V_2, E_1, E_2, E_3
10		Joystick speed controller	

The mode of operation and parameters are all set on the pump in its normal Pumping Program memory. Store the data as if it were a pumping program. Each mode of operation and parameter is stored in a separate and specific Pump Program Phase. The mode and parameters are stored in Pump Program Phases as pumping rates. To store a number as a pumping rate, select 'RATE' as the Pump Program Phase's 'Program Function'.

Example: Ramp With Voltage (Mode 1)
 Infusion rate range: 100 mL/hr to 500 mL/hr
 Voltage range: 0 to 7.5 V

In this mode, the pumping rate will be proportional to the voltage input.

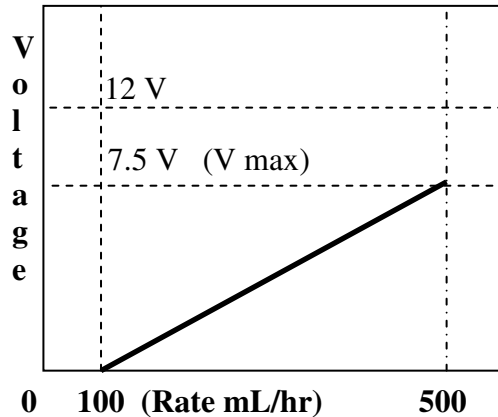

This example will be stored on the pump with the following format:

Pump Phase #	Rate Data	Parameter	Interpreted by Ana-Box™ as:
30	1.0 mL/hr		Mode 1
31	100 mL/hr	R ₁	100 mL/hr @ 0 V
32	500 mL/hr	R ₂	500 mL/hr @ 7.5 V
33	7.5 mL/hr	V _{max}	7.5 V Maximum voltage

Set 'Ramp with Voltage', Mode 1.

Select Pump Program Phase 30 (PH:30)

(Press and hold the 'Rate/Program Phase #' button for program entry mode)

Select 'RATE' function.

(Press 'Volume/Program Function' button, then use arrow keys to scroll through program functions)

Enter 1.0 as the pumping rate.

(Press 'Volume/Program Function' button to exit program entry mode)

For each parameter required for the selected mode, enter the parameters' data in the parameters' associated Pump Program Phase number. As above, select 'RATE' for each Phase's program function.

For the above example:

Phase 31: Set the pumping rate to 100 mL/hr for the rate at 0 V.

Phase 32: Set the pumping rate to 500 mL/hr for the rate at 7.5 V.

Phase 33: Set the pumping rate to 7.5 mL/hr, indicating the maximum voltage.

6.1. Mode 1: Ramp with Voltage

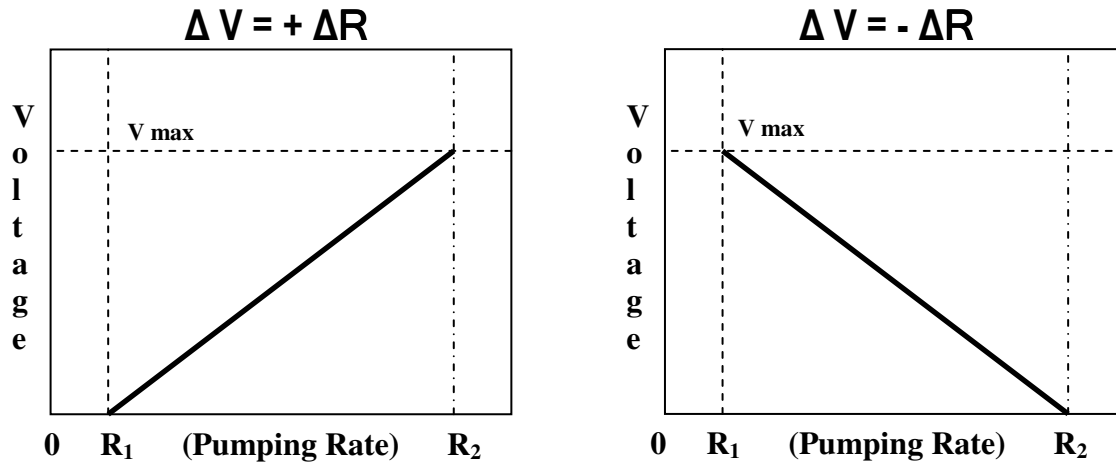

Ramp up or down the pumping rate with the Voltage. The pumping rate will be proportional or inverse proportional to the input voltage. The pumping rate will be updated 5 times a second.

Rate is proportional to Voltage: R_1 is minimum rate, R_2 is maximum rate

Rate is inverse proportional to Voltage: R_1 is maximum rate, R_2 is minimum rate

Note: Rate units for the minimum and maximum rates must be the same.

Parameter	Phase Stored	Description
R_1	31	Pumping rate when Voltage = 0 V
R_2	32	Pumping rate when Voltage = V_{max}
V_{max}	33	Voltage for R_2

6.2. Mode 2: Start Pump at Trigger Voltage

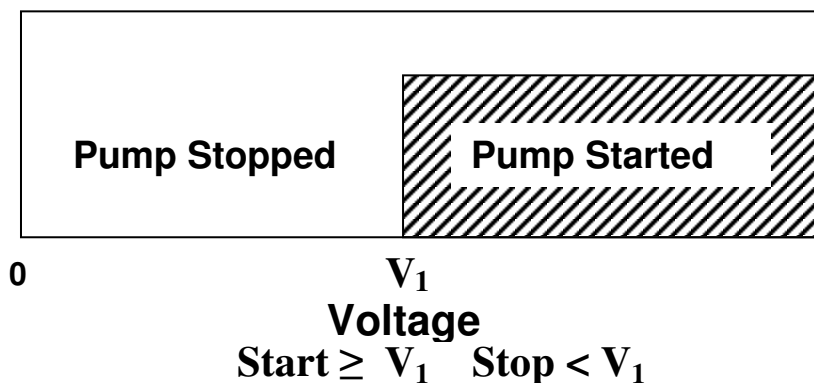

Sets a trigger voltage at which the pump will start.

<u>Parameters</u>	<u>Phase Stored</u>	<u>Description</u>
V_1	31	Voltage at, or above, to start the pump Below this voltage, the pump will be stopped

6.3. Mode 3: Stop Pump at Trigger Voltage

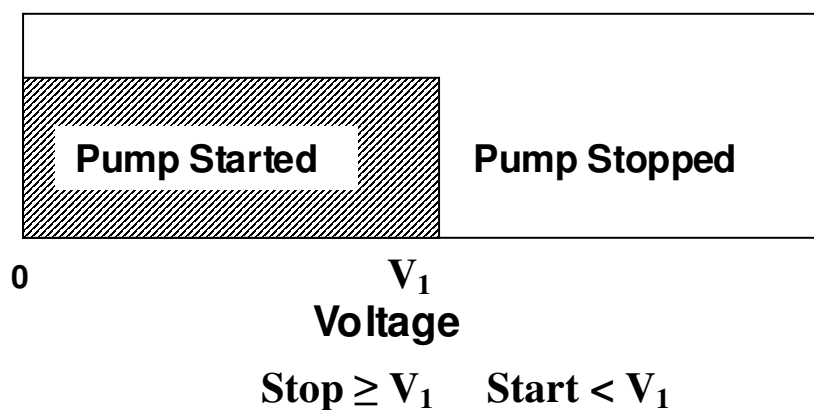

Sets a trigger voltage at which the pump will stop.

<u>Parameters</u>	<u>Phase Stored</u>	<u>Description</u>
V_1	31	Voltage at, or above, to stop the pump Below this voltage, the pump will be started

6.4. Mode 4: Start Pump within Voltage Range

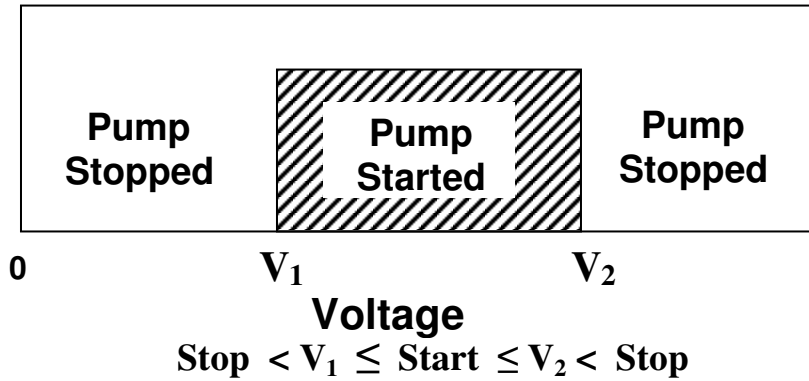

Sets a voltage trigger window within which the pump will start. Outside the voltage window, the pump will be stopped.

Parameters	Phase Stored	Description
V_1	31	Lower trigger window. Start at or above this voltage.
V_2	32	Upper trigger window. Start at or below this voltage.

6.5. Mode 5: Stop Pump within Voltage Range

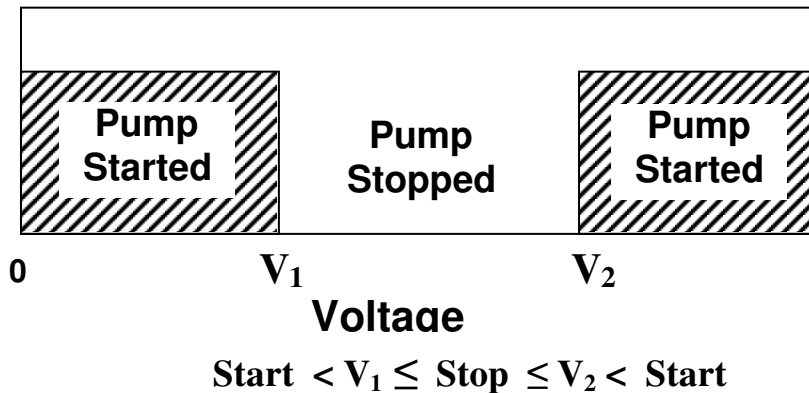

Sets a voltage trigger window within which the pump will be stopped. Outside the voltage window the pump will be started.

Parameters	Phase Stored	Description
V_1	31	Lower trigger window. Stop at or above this voltage.
V_2	32	Upper trigger window. Stop at or below this voltage.

6.6. Mode 6: Voltage Hold Negative Increment

$$+\Delta R < V_1 \leq \text{Steady } R \leq V_2 < -\Delta R$$

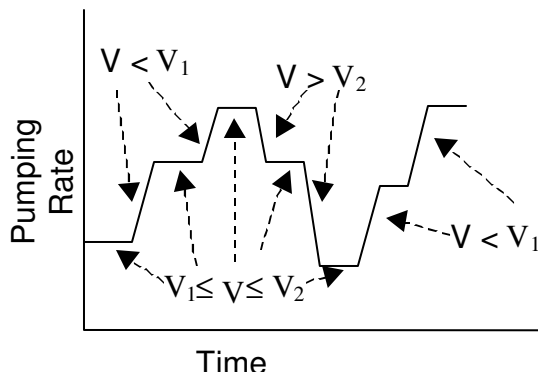

Adjusts the pumping rate to maintain a voltage window, such as from a pH meter or pressure meter. For example, as the pH increases above the V_2 voltage level, indicating high pH, the pumping rate decreases by ΔR to lower the pH. Below the V_1 voltage level, indicating low pH, the pumping rate will increase to raise the pH. Between the V_1 and V_2 voltage window, the pumping rate will be held steady.

This mode is the inverse of Mode 7. The pumping rate decreases instead of increases and increases instead of decreases.

Parameters	Phase Stored	Description
V_1	31	Lower trigger window voltage
V_2	32	Upper trigger window voltage
ΔR	33	Pumping rate Increment or Decrement value

When "Pump Control" starts, the current pump rate is used as the base rate, and then the pump is started. The pumping rate is updated 5 times a second.

Since the rate will be updated many times a second, a small number for the rate Increment or Decrement should be used to prevent radical rate changes. Start with a small number such as 0.1 for the rate change. The ΔR rate units will be ignored. This number will be added or subtracted to the current pumping rate.

6.7. Mode 7: Voltage Hold Positive Increment

$$-\Delta R < V_1 \leq \text{Steady R} \leq V_2 < +\Delta R$$

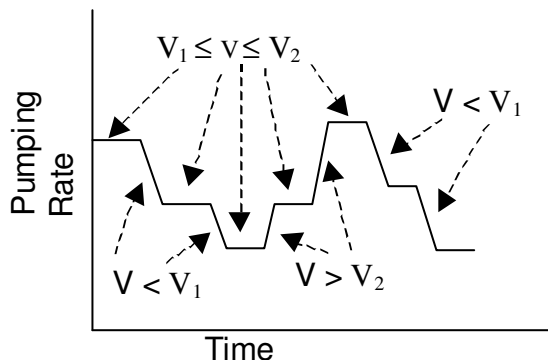

Adjusts the pumping rate to maintain a voltage window, such as from a pH meter or pressure meter. For example, as the pH increases above the V_2 voltage level, indicating high pH, the pumping rate increases by ΔR to lower the pH. Below the V_1 voltage level, indicating low pH, the pumping rate will decrease to raise the pH. Between the V_1 and V_2 voltage window, the pumping rate will be held steady.

This mode is the inverse of Mode 6. The pumping rate decreases instead of increases and increases instead of decreases.

Parameters	Phase Stored	Description
V_1	31	Lower trigger window voltage
V_2	32	Upper trigger window voltage
ΔR	33	Pumping rate Increment or Decrement value

When "Pump Control" starts, the current pump rate is used as the base rate, and then the pump is started. The pumping rate is updated 5 times a second.

Since the rate will be updated many times a second, a small number for the rate Increment or Decrement should be used to prevent radical rate changes. Start with a small number such as 0.1 for the rate change. The ΔR rate units will be ignored. This number will be added or subtracted to the current pumping rate.

6.8. Mode 8: Trigger Events at 1 Voltage Level

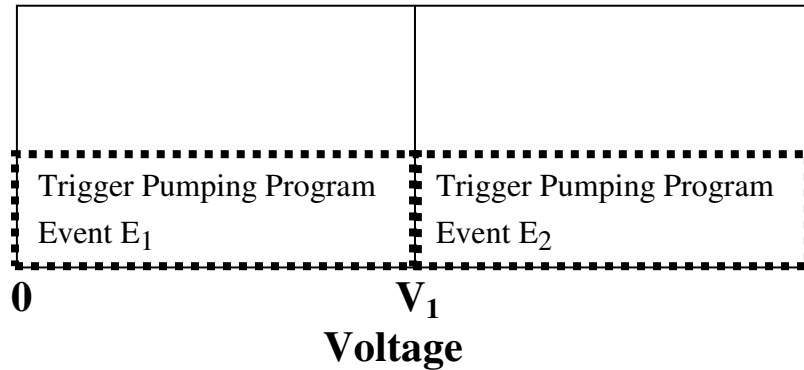

Pump Event Trigger $1 < V_1 \leq$ Pump Event Trigger 2

Trigger a Pump Program event at voltage trigger (V_1). When the voltage transitions above or below the voltage trigger, the relevant event is triggered.

If defined, the Pumping Program will immediately jump to the Pumping Program Phase defined by the relevant parameter E_1 or E_2 . If not defined, an event trap currently set in the Pumping Program by the Event function will be triggered.

After an event is triggered, there is a 0.10 V hysteresis before a new event can be triggered. This is to prevent ringing on the input causing rapid event triggers.

Parameters	Phase Stored	Description
V_1	31	Voltage trigger
E_1	35	Lower voltage Event: Pump Program Phase number
E_2	36	Upper voltage Event: Pump Program Phase number

Example

Withdraw at 500 mL/hr below 3V. Infuse at 100 mL/hr at or above 3V.

Phase	Pumping Rate	Volume	Direction	Description
1	100 mL/hr	0.000	Infuse	Event $\geq 3V$
2	500 mL/hr	0.000	Withdraw	Event $< 3V$
30	8.0 mL/hr			Mode 8
31	3.0 mL/hr			V_1 Voltage trigger
35	1.0 mL/hr			$< 3V$ Event jump to Phase 1
36	2.0 mL/hr			$\geq 3V$ Event jump to Phase 2

6.9. Mode 9: Trigger Events at 2 Voltage Levels

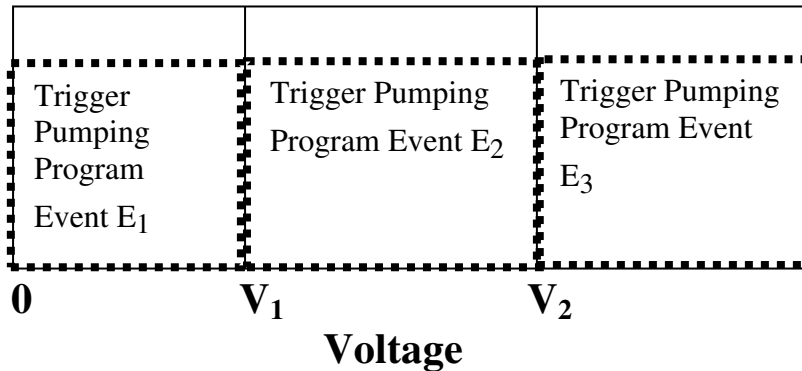

Pump Event 1 < V₁ ≤ Pump Event 2 < V₂ ≤ Pump Event 3

Trigger a Pump Program event at voltage trigger (V₁) or (V₂). When the voltage transitions above or below the voltage triggers, the relevant event is triggered.

If defined, the Pumping Program will immediately jump to the Pumping Program Phase defined by the relevant parameter E₁, E₂, or E₃. If not defined, an event trap currently set in the Pumping Program by the Event function will be triggered.

After an event is triggered, there is a 0.10 V hysteresis before a new event can be triggered. This is to prevent ringing on the input causing rapid event triggers.

Parameters	Phase Stored	Description
V ₁	31	Voltage trigger
V ₂	32	Voltage trigger
E ₁	35	Lower voltage Event: Pump Program Phase number
E ₂	36	Middle voltage Event: Pump Program Phase number
E ₃	37	Upper voltage Event: Pump Program Phase number

Example

Withdraw at 500 mL/hr below 3V. Infuse at 100 mL/hr at or above 3V. Withdraw at 950 mL/hr at or above 4V.

Phase	Pumping Rate	Volume	Direction	Description
1	100 mL/hr	0.000	Infuse	Event ≥ 3V
2	500 mL/hr	0.000	Withdraw	Event < 3V
3	950 mL/hr	0.000	Withdraw	Event ≥ 4V
30	9.0 mL/hr			Mode 9
31	3.0 mL/hr			V ₁ Voltage trigger
32	4.0 mL/hr			V ₂ Voltage trigger
35	1.0 mL/hr			< 3V Event jump to Phase 1
36	2.0 mL/hr			≥ 3V Event jump to Phase 2
37	3.0 mL/hr			≥ 4V Event jump to Phase 3

6.10. Mode 10: Joystick Speed and Direction Control

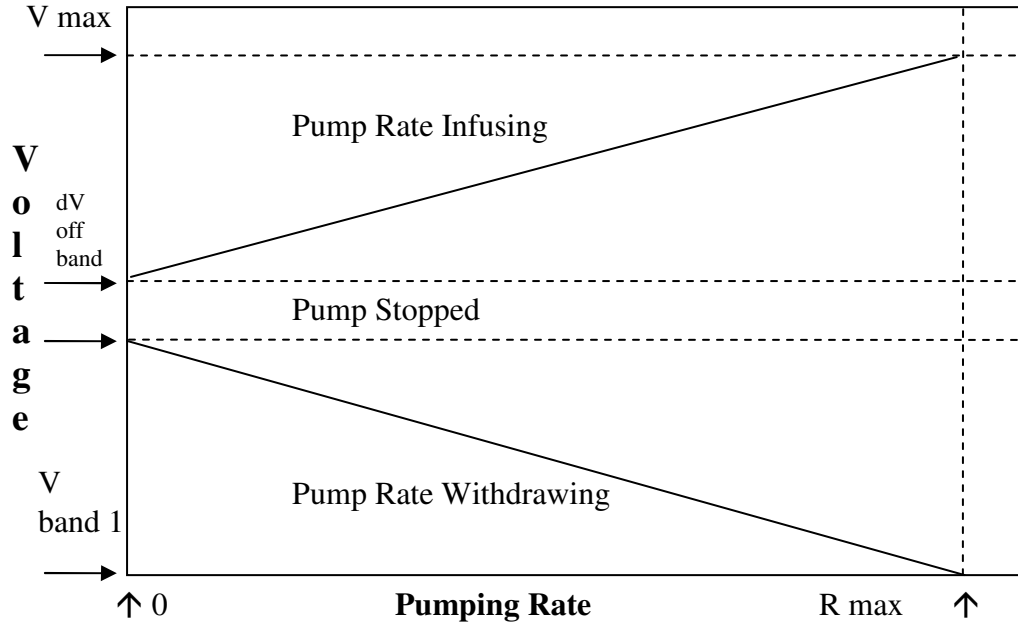

Permits a joystick type of device to be used to control the pump speed and direction. Pushing forward from the central position will start the pump infusing, starting slow, and then increasing in speed. Pulling backward from the central position will start the pump withdrawing, starting slow, and then increasing in speed. The neutral central position will stop the pump.

Parameter	Phase Stored	Description
R max	31	Pumping rate when Voltage = 0 V or V max
V band 1	32	Maximum pump withdraw band voltage
V max	33	Maximum voltage
dV band off	34	Pump stopped delta voltage band

7. Sub-Modes of Operation

Sub-Modes of Operation are selected by adding the sub-mode control code to the selected Pump Operational Mode. For example, to select sub-mode 0.1, with Pump Operational Mode 1, set the mode, specified with Pump Phase 30, to 1.1 ml/hr.

7.1. Allow “Pump Control” Disable Sub-Mode 0.1

In an automated pumping system, states may exist where external pump control needs to be disabled. For example, in an automated infusion and withdrawal application, the pump only needs to be controlled while infusing, but not while refilling the syringe. In other situations, the pump may need to be synchronized with other equipment and automatic pump starting needs to be disabled until it is ready.

Pin 6, Program Input, on the pump's TTL connector is used to disable Pump Control. With the "Pump Control" switch set to "RUN", when a logic 0 (short to ground) on this pin is read by the Ana-Box™ and "Disable" sub-mode is set, Pump Control mode is stopped, indicated by the LED blinking. When this pin returns to logic 1 (disconnect from ground), Pump Control is re-started, indicated by a solid LED.

To set "Disable Pump Control" sub-mode, add 0.1 to the Operational Mode setting.

For example, if Ramp With Voltage, Mode 1, is the Operational Mode, set the Operational Mode to 1.1.

Note: The logic state of Pin 6 will be sampled every 200 or 400 milliseconds, depending on the operational mode. Also, use of this mode will slow down the pumping rate update for modes that control the pumping rate.

To prevent synchronization problems, set the logic level before control needs to be disabled, or provide a delay afterwards. Otherwise, a rate command can be sent to the pump after the setting of the logic pin, but before it is sampled by the Ana-Box.

See section 9.2 Disable "Pump Control" Example, for an example application using the Disable sub-mode.

7.2. Infuse Only "Pump Control" Sub-Mode 0.2

Mode 1 Only: The pump will only be controlled while the pump is infusing. This mode would be useful in applications that require infusion under analog control, but refills a syringe at a higher pumping speed.

To set "Infuse Only" Pump control sub-mode, add 0.2 to the Operational Mode setting. Mode Setting: 1.2

7.3. Disable Beep for Parameter Confirmation Sub-Mode 0.01

This mode prevents the pump from beeping every time the Ana-Box™ is started.

To set "Disable Confirmation Beep", add 0.01 to the Operational Mode setting. For example Mode 1 with beep disabled would be Mode: 1.01

7.4. Disable Voltage Level Shifts Sub-Mode 0.02

Forces the Ana-Box™ to limit the maximum input voltage to 2.4V

Certain input devices such as potentiometers can interfere with the Ana-Box™'s voltage level shifting. This mode disables voltage level shifting by limiting the maximum input voltage to 2.4V.

8. Computer Data logging

-It is not necessary to have a computer attached –

The Ana-Box™ periodically transmits status information which can be captured and parsed by a data logger or computer. A terminal emulator program, which comes standard with most computers, can be used to view and capture this information.

Set the terminal emulator's communication parameters as follows:

Baud Rate: 19,200
Data Frame: 8N1
Flow Control: None

The status information is transmitted as ASCII text strings. The text strings are structured in a predictable format to facilitate text parsing by a data logger. Each string is terminated by a carriage return <CR> and line feed <LF>.

The format of the output string (except for diagnostics mode) is:

<type> : <data> <CR> <LF>

Legend:

<type>	1 or 2 digit number representing the type of data
<data>	Descriptive text string
{nnnn}	Floating point number, 4 digits plus a decimal point
{units}	Flow rate units: "uL/hr" "mL/hr" "uL/min" "mL/min" Voltage units: "V"
{pump model}	Text string representing the pump model name
<CR>	Carriage return (hex 0D)
<LF>	Line feed (hex 0A)

When power is first applied to the Ana-Box™, the following is transmitted:

0: ANA-BOX(TM) 1.0 V2.12

When the attached pump is sensed, the pump model is transmitted:

1: {pump model}

When "RUN" is selected on the "Pump control" switch, the pump's setup information is transmitted, or the default settings if the pump was not configured. If communications cannot be established with a pump, or no pump is attached, diagnostics mode is entered. When communications is established with the pump, the following setup information is transmitted:

11: n=MODE
 12: 1={nnnn} {units}
 12: 2={nnnn} {units}
 12: 3={nnnn} {units}
 12: 4={nnnn} {units}
 12: 5={nnnn} {units}
 12: 6={nnnn} {units}
 12: 7={nnnn} {units}

After pump control starts, the following are the text strings that are transmitted:

Current pump rate (transmitted once per second in modes 1, 6, and 7)

22: <pump rate> <pump rate units>

Additional information is transmitted whenever a status change event occurs.

"Pump Control" switch changes:

23: 0 STOP KEY "STOP" key selected
 23: 1 START KEY "RUN" key selected

"Pump Control" changes to the pump's operation:

20: START PUMP
 21: STOP PUMP

Pump operation status changes detected from the pump:

30: PUMP ALARM
 31: PUMP STOPPED
 32: PUMP STARTED

Diagnostics Mode

If communications cannot be established with an attached pump, diagnostics mode is entered. In this mode, the current voltage reading is transmitted once per second. The format for the voltage is:

<nn.nnn> <CR> <LF>

9. Special Applications

9.1. Proportional Pumping: Dual Pump Constant Flow Rate

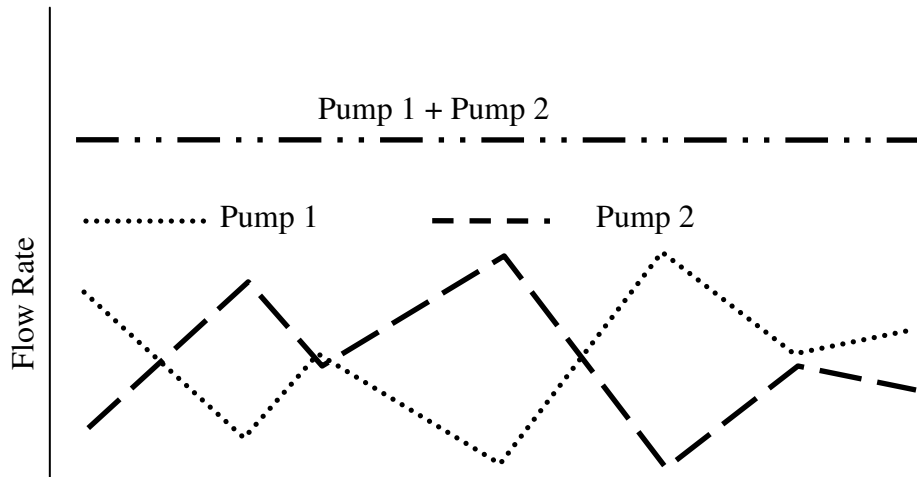

Create a closed loop, constant flow rate system, which can vary the concentration of a chemical in reaction to a sensor, such as a pH meter or pressure meter.

The system is created using 2 pumps, one for the full strength chemical and a second for the dilution fluid. An Ana-Box™ would be attached to each pump, but share a common voltage source. Each pump would be set for Mode 1 operation, with one pump set to positive ramp with voltage, and the other set to negative ramp with voltage.

In this configuration, as one pump increases in flow rate in reaction to an increasing voltage source, the other pump would decrease in flow rate in reaction to the same voltage source. The result summation of the 2 pumps would be a constant flow rate, but with a chemical concentration that is proportional to the input voltage.

9.2. Disable “Pump Control” Example

This example expands on the previous example, turning it into a fully automated system by allowing the pumps to automatically refill the syringes. To create an automated refill system, dual check valves are added to each syringe, with the inflow lines attached to reservoirs. In addition, a logic cable is attached to the TTL logic connectors on each pump to synchronize the system.

To set the “Disable” sub-mode, 0.1 is added to the operating mode of each pump. Therefore, the operating mode is set to 1.1 and stored in Phase 30 on each pump.

The following program is setup on each pump:

Phase #	Function	Rate	Volume	Direction	Description
1	OUT.0				Disable Pump Control
2	PS:01				1 second pause
3	RATE	1500 mL/hr	50 mL	Withdraw	Refill syringe
4	OUT.1				Enable Pump Control
5	RATE	1 mL/hr	50 mL	Infuse	Base infusion rate
6	JP:01				Return to Phase 1

While refilling, the "OUT" function disables Pump Control, then re-enables Pump Control when the syringe is refilled. The purpose of the 1 second pause is for synchronization. This pause allows the Ana-Box™ time to read the status of the disable pin before the start of the refill phase, preventing a change in the pumping rate during refill.

To complete this system, a TTL logic cable with a DB-9 connector on each end is needed between the pumps. The following is the wiring for the TTL logic cable:

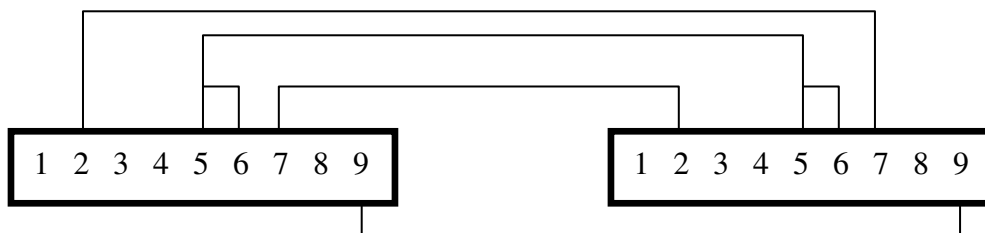

The "OUT" program function sets the logic level of pin 5. Pin 5 of both pumps is attached to pin 6 of both pumps. Therefore, if either pump disables Pump Control, then Pump Control will be disabled on both pumps. Attaching pins 2 and 7 to each other synchronizes starting and stopping of the pumps. If either pump starts or stops, then the other will start or stop.

10. Technical Specifications

10.1. RJ-11 Connector Wiring

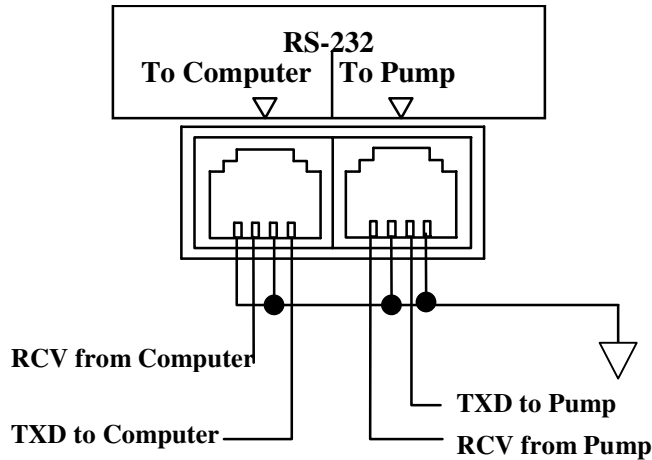

PC Com Port Connectors

25 Pin

- 3 - Receive
- 2 - Transmit
- 9 - Ground

9 Pin

- 2 - Receive
- 3 - Transmit
- 5 - Ground

- Connect to "To Computer" TXD
- Connect to "To Computer" RCV
- Connect to "To Computer" GND

10.2. Ratings and Limits

Analog Input

- Maximum operational DC input voltage: 12 V
- Absolute maximum DC input voltage: 24 V
- Current draw from Analog Voltage Input:
 - 0-2V < 2µA
 - 2-5V < 1mA
 - 5-8V < 2mA
 - 8-12V < 3mA

Communications

- Pumping rate update: 5 Hz (maximum)
- BAUD rate: 19,200
- Data frame: 8N1

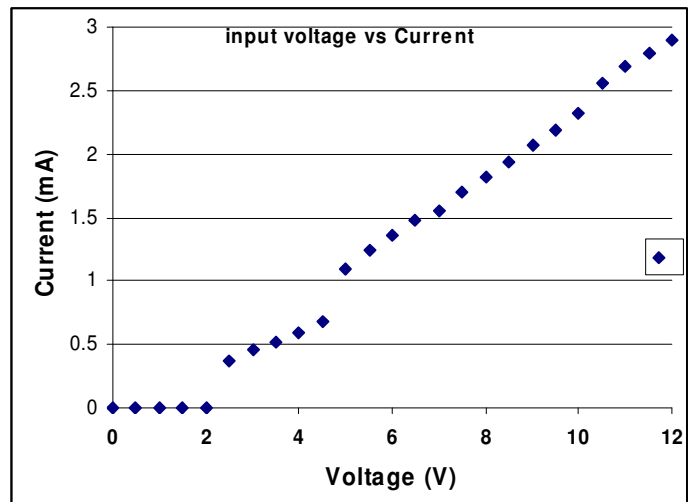

Physical

- DC Power supply: Voltage: 12V
Connector: 2.1 mm, center positive socket
- Power to Pump connector: Length: 6
Type: 2.1 mm, center positive barrel

Analog Input Connectors: Maximum wire gauge: 18 AWG

Ana-Box™ Size: 4" x 3" x 1" (L x W x H)
Weight: 5 Ounces.