

Q-sep™ 3000 Centrifuge

Centrifuge Operator's / Service Manual cat. # 26230 & 26231

*NOTE: The programmable run-time
has been preset for*

5 MINUTES

Instructions to change this are located on page 6



The Q-sep™ 3000 centrifuge complies with all requirements of UL standard 3101-20, Can/CSA C22.2 No. 1010.1, and Can/CSA C22.2 No. 1010.2.20.

HRMalytic +61(0)3 9762 2034 09
AUSTRALIAN Distributors **ECHnology** www.chromtech.net.au

Table of Contents

Precautions & Model Description	2
Supplied Equipment	3
Available Features	3
Specifications	3
Control Panel	4
Setup Location	5
Initial Setup Procedure	5
Additional Setup Procedure	6
Operation	6
Tube Holder Configurations	7
Balanced Loads	7
Care and Preventative Service	8
Rotor Removal and Installation	9
Safety Features	10
Emergency Rotor Chamber Entry	10
Troubleshooting	11
Replacement Parts	11
Warranty	12

Model Description

The Q-sep™ 3000 centrifuge is a continuous-duty, electronically-controlled, single speed, horizontal laboratory centrifuge with a lid safety interlock system. The unit is controlled by an electronic push-button timer that is variable from 1 to 30 minutes, for precise spin times and ease of use. Samples can be safely viewed through the transparent lid. The imbalance detection system safely terminates a run cycle in the event that a load is severely imbalanced. Entry into the machine is restricted during operation by the safety interlock system. The Q-sep™ 3000 centrifuge features a lighted control panel that displays the status of the machine, easily viewable from a distance. Finally, a cycle counter keeps a count of the total number of machine runs for servicing and maintenance records.

PRECAUTIONS:

1. Do not attempt to unlatch the centrifuge lid unless the “Unlocked” indicator light is illuminated (see pg. 4).
2. Avoid solvent contact with centrifuge lid.
3. Insure that the weight load is balanced before running the centrifuge (see pg. 7).

Quick Start Guide

1. Choose a well ventilated area for setup.
2. Plug centrifuge into properly grounded receptacle.
3. Press “POWER” button (light will illuminate).
4. Press “OPEN/EMERGENCY STOP” button to disengage locking system and verify that the rotor is not moving. The “UNLOCKED” light will appear red. It is now safe to open the lid.
5. Turn latch counter-clockwise to open lid.
6. Place tube holders in rotor and verify they are seated properly.
7. Place centrifuge tubes in the tube holders and ensure that the weight load is balanced.
8. Close lid and turn latch knob clockwise to lock position (“LATCH” indicator light will illuminate).
9. Press “START” button to initiate operation (“RUN” indicator light will illuminate).
10. Centrifuge will spin for 5 minutes (to adjust spin time, see page 6).
11. When the rotor has come to a full stop, a beeper will sound, the “RUN” indicator will turn off, and the “UNLOCKED” indicator light will illuminate for 60 seconds. Turn lid knob counter-clockwise to open the lid and remove samples.
12. If centrifuge locks again before samples are removed, press “OPEN/EMERGENCY STOP” button to disengage locking system. The “UNLOCKED” light will illuminate and the lids can now be opened.

 **HROMalytic** +61(0)3 9762 2034 09
AUSTRALIAN Distributors **ECH**nology www.chromtech.net.au

Q-sep™ 3000 Supplied Equipment*

The following items come standard with each Q-sep™ 3000 centrifuge:

1. One (1) six place horizontal rotor
2. Six (6) 50mL single-place tube holders
3. Six (6) 50mL conical tube inserts
4. Six (6) 15mm four-place tube holders
5. Twenty four (24) 2mL tube adapters
6. One (1) Operator's Manual



See page 11 for replacement part catalog numbers and ordering information.

*The rotor and rotor accessories are rated for a rotation frequency of 4,130 rpm, (a force of 3000 xg with the 15mm tube holders).

Q-sep™ 3000 Available Features

- Swing-out horizontal rotor design incorporating a unique test tube holder that produces **horizontally separated samples** while requiring no additional parts.
- Fixed-speed of 4,130 rpm (3,000 xg).
- Cool-flow air flow design that prevents overheating of samples.
- Heavy gauge steel construction for safety and durability.
- Lid safety switch that prevents the centrifuge from operating unless the lid is closed and latched.
- Removable rotor for easy cleaning.
- Locking lid that allows entry into the centrifuge only after the rotor has completely stopped.
- Brushless DC motor; requires no routine maintenance, cool running.
- Clear lid for safe observation of samples and optical calibration of speed.
- Electronically controlled timed operation, variable from 1 to 30 minutes.
- Push-button operation.
- Indicator lights:

"RUN"	green	-lights when power is applied to the motor
"LATCH"	yellow	-lights when the lid is closed and latched
"UNLOCKED"	red	-lights when the lock system is deactivated
- Cycle counter to monitor machine use.
- Audible indicator at the end of each run.

Q-sep™ 3000 Specifications

Motor Speed and Force Rating: 4,130 rpm, 3,000 xg

Maximum Capacity with 6-Place Horizontal Rotor: 6 x 50ml tubes, 18 x 15ml tubes, 24 x 2ml tubes

Motor: 1/2 H.P. brushless DC

Nominal Acceleration Time: 45 seconds

Nominal Braking Time: 120 seconds

Timer (electronic): 1 to 30 minutes +/-1%

Requirement: 2.0 or 1.0 amps

Current Voltage Requirement: 115 or 230 (+/-10%) volts

Frequency: 50 / 60 Hz

Centrifuge Protection Breaker: 4 amp re-settable

Overall Dimensions (H x W x D): 9 in (22.9cm) x 14.5 in (36.8cm) x 17 in (43.2cm)

Weight: 39 lbs (17.7kg)

HROMalytic +61(0)3 9762 2034 09
AUSTRALIAN Distributors **ECHnology** www.chromtech.net.au

Control Panel

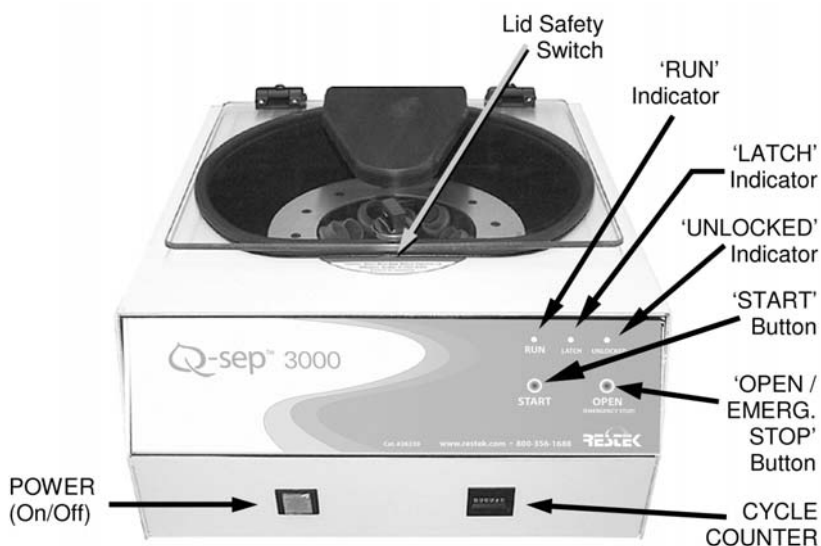

Power (on/off) Button: This button controls the power to the centrifuge. The power is on when the button is illuminated.

"Run" Indicator: Lights up when the centrifuge is in operation (power is being applied to the motor).

"Latch" Indicator: Lights up when the lid has been closed and latched properly.

"Unlocked" Indicator: Lights up to indicate that the locking mechanism has been deactivated, allowing access to the rotor chamber.

"Start" Button: Begins a new run (the lid must be closed).

"Open/Emergency Stop" Button: Allows access to the rotor chamber by disengaging the locking mechanism. Entry is only permitted when the rotor is stopped. Pressing this button during operation will terminate the run and unlock the lid when the rotor has come to a stop.

Lid Safety Switch: The lid safety switch prevents the centrifuge from operating while the lid is open. If the knob is not turned completely clockwise to its stop position, the centrifuge cannot operate. Programming functions are accessed by first opening the lid safety switch.

Cycle Counter: This counter increments once for each run of the centrifuge. This count is used for both warranty purposes and routine maintenance.

Setup Location

1. Unpack the centrifuge and verify that all of the supplied equipment is present.
2. Choose a setup location which meets the following criteria:
 - a) A bench top clearance height of 24" (60cm) is required in order to open the lid.
 - b) The clearance envelope is the space around the centrifuge which is required for safety. Choose a setup location which will allow for a clearance envelope of at least 30" (76cm) x 30" (76cm), with the centrifuge at the center. No person or hazardous material should be permitted in the clearance envelope during operation. The operator time within the envelope should be limited to the time necessary for loading, unloading, and centrifuge operation only.
 - c) Proper ventilation is necessary to prevent the overheating of samples as well as premature failure of the centrifuge. Choose an area which will allow unencumbered air flow.
 - d) No adjustment is necessary for leveling the centrifuge; however, the surface should be flat and level.
 - e) Be sure the outlet is always within reach as the power cord is only the means of emergency disconnection!

Initial Setup Procedure

If any problems are found during the initial setup procedure, refer to the troubleshooting section on page 11.

1. Plug the power cord into the rear of the centrifuge. Plug the other end into an approved electrical outlet.
For electrical safety, the unit must always be properly grounded.
2. Engage the power button on the front of the centrifuge (lower left-hand side).
The button will illuminate when it is activated.
3. For safety purposes, the locking system is always activated. To deactivate the system (in order to insert or retrieve samples) press the "OPEN / EMERGENCY STOP" button on the control panel. The "UNLOCKED" indicator light should illuminate. If it does not, refer to page 11 on troubleshooting. The lid will be unlocked for 15 seconds after pushing the "OPEN/EMERGENCY STOP" button.
4. Turn the latch counter-clockwise and open the lid.
5. Spin the rotor by hand; check for free and level rotation. If the rotor does not spin freely, refer to page 11 on troubleshooting.
6. Check the thumb screw in the middle of the rotor and make sure that it is tight.
7. Place the test tube holders inside the rotor and verify that they are seated properly.
8. Close the lid. Rotate the lid knob clockwise to its complete stop position. The 'LATCH' indicator light should be illuminated. If it is not, make sure that the lid is latched properly. The centrifuge will not run unless the lid is latched and the "LATCH" light is on.
9. Turn the centrifuge on by pushing the "START" button.
10. The "RUN" indicator light will illuminate.
11. The unit will accelerate to its set speed.
12. Listen to the sound of the centrifuge. A smooth whirring sound should be heard. If there are any loud or unusual sounds, stop the centrifuge by pushing the "OPEN / EMERGENCY STOP" button immediately and refer to page 11 on troubleshooting.
13. While the machine is running, try to turn the latch counter-clockwise. Power may be cut to the motor but you should not be able to fully turn the latch. If it is possible to turn the latch and open the lid while the unit is running, contact Restek Corporation or your local distributor. Close and latch the lid.
14. Push the "OPEN / EMERGENCY STOP" button. The "RUN" indicator light should go out and the motor should slow to a stop.
15. The lid should remain locked until the rotor has stopped. If the machine unlocks prematurely, contact Restek Corporation or your local distributor. Once the rotor has stopped, a beeper will sound and the interlock system will become disengaged for sixty (60) seconds. The "UNLOCKED" indicator light will be illuminated during this time.
16. To gain entry into the centrifuge after this period has ended, simply press the "OPEN / EMERGENCY STOP" button. The lid will unlock for fifteen (15) additional seconds. Repeat if necessary.

After the centrifuge has passed this procedure, it is ready for operation.

If you would like to make adjustments to your machine's settings, please continue on to "Additional Set-Up Procedures".



Additional Setup Procedures (Optional)

1. Verify the Run Time Preset:

NOTE: The centrifuge must be plugged in and the lid must be opened to access programming functions!

- a. Push and hold the "START" button for approximately three (3) seconds. The "LATCH" indicator light will begin to flash, indicating the centrifuge is in program mode.
- b. When you release the "START" button, the "RUN" indicator light will begin to flash. Each flash of the "RUN" indicator light represents one minute of run time. If the time indicated is not desired, follow the instructions below to change it.

2. Change the Preset Run Time

NOTE: The centrifuge must be plugged in and the lid must be opened to access programming functions!

- a. Push and hold both the "START" and "OPEN / EMERGENCY STOP" buttons for approximately three (3) seconds. The "LATCH" indicator light will begin to flash, indicating the centrifuge is in program mode. Release the two buttons.
- b. Press the "START" button once for each minute of desired run time. The "RUN" indicator light will flash once for each entered minute.
- c. Press the "OPEN / EMERGENCY STOP" button to save the change and exit programming mode.
- d. If desired, use the "verify the preset run time" procedure above to confirm that the adjustment is correct.

Q-sep™ 3000 Centrifuge Operation

NOTE: Follow the initial setup procedure on page 5 before initial operation.

1. Plug the centrifuge into an approved 115 volt (cat. # 26230) or 230 volt (cat. #26231) AC, 50/60 Hz outlet and press the "POWER" button.
2. Push the "OPEN / EMERGENCY STOP" button, verify the rotor is not running, and then open the lid.
3. Place the test tube samples into the tube holders. Be sure to follow the rules for balanced loads on the next page.
4. Close the lid and turn the lid knob clockwise to its complete stop position.

The "LATCH" indicator light should turn on to indicate that the latch is closed properly.

If the lid knob is not completely latched, the "LATCH" indicator light will not turn on and the centrifuge will not operate!

1. Turn the machine on by pushing the "START" button on the control panel.
2. The centrifuge should begin to spin. The "RUN" indicator light should illuminate.

IF A PROBLEM IS FOUND DURING A SPIN THAT REQUIRES THE CENTRIFUGE TO SHUT DOWN, PRESS THE "OPEN / EMERGENCY STOP" BUTTON!

1. The run indicator light will begin to flash when one minute remains in the cycle.
2. After the set time has elapsed, the "RUN" indicator light will extinguish and the rotor will brake to a complete stop.
3. The "UNLOCKED" indicator light will illuminate, a beeper will sound, and the locking mechanism will disengage allowing entry into the rotor chamber. If it does not, refer to page 11 on troubleshooting.
4. Turn the lid knob counter-clockwise and open the lid.
5. Remove the samples.
6. If the machine re-locks before the samples are removed, press the "OPEN / EMERGENCY STOP" button to unlock the lid for an additional fifteen (15) seconds. Repeat if necessary.

Tube Holder Configuration for Q-sep™ 3000 Centrifuge

The Q-sep™ 3000 centrifuge has been designed to work with 50, 15, and 2mL centrifuge tubes using the appropriate accessories. The purple tube holders are designed to hold 50mL round or conical bottom centrifuge tubes. Up to 6, 50mL tubes can be processed at the same time.* The red tube holders and 4-position inserts are designed to hold 15mL round or conical bottom centrifuge tubes. Up to 18, 15mL tubes can be processed at the same time. When processing 15mL tubes, one of the positions in the tube holder must be left empty to prevent the tubes contacting each other when the holder moves into the horizontal position. Note that either the left or right position may be left empty, but must be consistent across all holders to maintain a balanced load. Purple inserts can be used to adapt the red tube holder for use with 2mL round or conical bottom centrifuge tubes. Up to 24, 2mL tubes can be processed at the same time using these inserts.

Different sizes of tubes can be processed simultaneously, as long as the balance is properly maintained (see Balanced Loads below).

Balanced Loads

Your centrifuge must contain a balanced load in order to work properly. To insure that the load is balanced, keep these rules in mind when inserting test tube samples:

1. Opposing tube holders must be identical.
2. Opposing tube holders must be empty or loaded with an equal number of equally weighted samples.
3. If an odd number of samples is to be spun, use a water-filled tube balance with the unpaired one.
NOTE: The Q-sep™ 3000 centrifuge is designed to detect serious out-of-balance situations and will safely terminate an unbalanced run by cutting the power to the motor. If this occurs, wait for the rotor to stop spinning before unlocking. Balance the load before restarting the centrifuge motor.
4. When loading tubes into opposing holders, the holders will be balanced when the tubes are loaded diagonally from one another. See the illustration below.

Note: When loading 15mL tubes, the maximum capacity is three (3) tubes per carrier. Keep the lower right side position empty to prevent tubes from contacting each other when the carrier moves to the horizontal position.

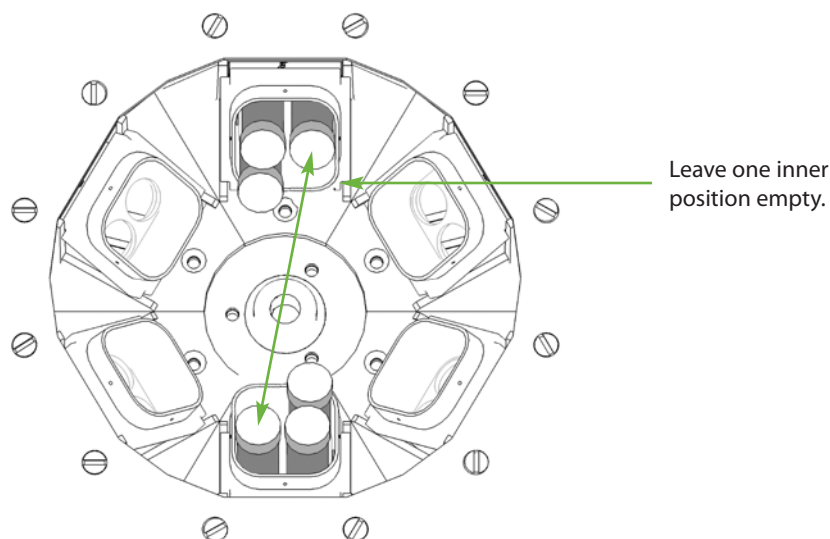

*When using 50mL conical bottom centrifuge tubes, place conical tube inserts into the bottom of the 50mL tube holder to prevent damage to the centrifuge tubes.

HRMalytic +61(0)3 9762 2034 09
AUSTRALIAN Distributors **ECH**nology www.chromtech.net.au

Care and Preventative Service

With proper care and maintenance, your Q-sep™ 3000 centrifuge will provide years of laboratory service. For proper care, the following steps should be taken:

1. **Provide Adequate Ventilation:** For cooling purposes, the Q-sep™ 3000 centrifuge draws in ambient air through the rear of the lid and exhausts this air out the rear of the base. Do not block the rear of the centrifuge as this will not allow the machine to properly ventilate itself.
2. **Always Spin Balanced Loads:** Make certain that opposing tube holders are filled with an equal volume sample or an equivalent weight water-filled tube. The Q-sep™ 3000 centrifuge has a cushioned motor mounting design which, along with its rubber feet, produces excellent vibration dampening. However, out-of-balance loads may break glass test tubes and may produce unsatisfactory separation results. Proper load balancing will improve sample separation and extend the life of the centrifuge. Refer to page 7 for additional information on balancing the load.
3. **Keep the Tube Holders Clean:** NOTE: Always follow the safety guidelines of your laboratory to properly clean up and/or dispose of materials, if a substance known to be potentially toxic is spilled in or on the centrifuge. If a spill occurs in the centrifuge or tube holder, thoroughly clean the rotor and both the inside and outside of the tube holder or replace the tube holder if necessary. Replacement parts can be found on page 11.
4. **Motor and Electrical Maintenance:** The Q-sep™ 3000 centrifuge uses a brushless DC motor with high quality electrical components. It should not need service for the life of the centrifuge.
5. **Keep the Rotor Chamber Clean:** Every six months, or whenever a tube breaks, (refer to the note in #3), it may be necessary to remove the rotor and clean the rotor chamber. Follow the instructions on page 9 to remove and reinstall the rotor.

CAUTION DURING CLEANING: Once the lid has been opened, unplug the power cord from the electrical outlet to eliminate the risk of electric shock during cleaning.

The rotor chamber, rotor, and accessories should be thoroughly cleaned using either methanol, and/or soap and water. The use of halogenated solvents, ketones, esters, or other solvents not prescribed by the manufacturer may cause damage to the rotor and tube holders and should not be used.

Apply cleaning solutions with a towel or cloth. **Do not submerge the centrifuge in water or other cleaning solutions as this will cause damage and void the warranty!**

6. **Rotor and Tube Holders:** It is recommended that the tube holders be replaced after 24 months of use or 25,000 cycles, whichever comes first. Periodically check the thumb screw in the center of the rotor to ensure that it remains tight.

Rotor Removal and Installation

To remove the rotor:

1. Unlock the centrifuge by pushing the "OPEN / EMERGENCY STOP" button, then unlatch and open the lid.
CAUTION: Unplug the centrifuge from the electrical outlet at this time to eliminate the possibility of electrical shock or other injury.
2. Remove the test tube holders.
3. Remove the thumb screw in the center of the rotor.
4. Pull up on the rotor until it is clear of the motor shaft.
5. Remove the rotor from the rotor chamber.

To install the rotor:

1. Place the rotor straight down onto the motor shaft, taking care to line up the slot in the bottom of the rotor with the pin in the motor shaft (see picture). The rotor should slide onto the shaft freely and the rotor should be level.
Be sure that the slot in the underside of the rotor lines up with the pin going through the motor shaft or the centrifuge may be damaged!
2. Once a proper fit has been achieved, replace the thumb screw and tighten. The thumb screw must be properly tightened or the rotor may be damaged.
3. Replace the tube holders and verify that they are seated properly.



The slot in the bottom of the rotor must be aligned with the pin in the motor shaft!

4. It is recommended that the initial setup procedures on page 5 be performed to ensure that the rotor has been installed correctly and that no damage has been done to the centrifuge during the rotor installation or chamber cleaning.

Safety Features

Lid Safety Switch: The Q-sep™ 3000 centrifuge lid is secured to the top of the cabinet by a latching knob and pawl system. When the knob is rotated clockwise, the pawl grips the underside of the cabinet opening and prevents the lid from opening. A mechanical stop positions the pawl and prevents it from rotating completely. When rotated to the stop position, the pawl makes contact with a micro-switch mounted underneath the cabinet top. The lid safety switch prevents the centrifuge from operating while the lid is open. An indicator light on the front of the machine will illuminate when the lid has been latched properly.

Lid Safety Interlock System: In addition to the Lid Safety Switch, the Q-sep™ 3000 centrifuge has a true “0 rpm” lid-locking system. The lid safety interlock system keeps the lid locked at all times (even during power failure) and requires that the rotor be at rest in order to unlock the lid. The centrifuge will not allow entry into the rotor chamber unless the centrifuge has power and the rotor is stopped. To open the lid, make sure that the centrifuge is plugged in and, with the rotor stopped, press the “OPEN / EMERGENCY STOP” button.

*Note: After the centrifuge has started spinning, it may be possible to rotate the lid knob enough to cause the pawl to lose contact with the lid safety switch. If this happens, the centrifuge motor may lose power, **but the lid will still remain locked.** If the knob is accidentally moved and this situation should occur, rotate the knob fully clockwise to its stop position and the centrifuge will resume operation after a few seconds.*

Circuit Breaker: The Q-sep™ 3000 centrifuge is protected with a 4 amp circuit breaker located at the rear of the machine and mounted to the base. Any electrical short circuit will cause the breaker to cut power to the machine.

Imbalance Detection System: In the event that an imbalanced load is spun in this centrifuge, the run will be aborted. A continuous, two-count flash of the run and latch indicator lights signals that an imbalance was detected. Once the centrifuge has safely come to a complete stop and unlocked, press the “OPEN” button or open the lid to reset the fault. Correct the imbalance before proceeding.

Emergency Rotor Chamber Entry: In the event of power failure, it may be impossible to unlock the lid by conventional means. In this case, entry into the rotor chamber may be made by removing the latch label and using a pen to manually disengage the locking mechanism (see photo). Pull the mechanism towards the control panel, then unlatch and open the lid. If the unit is damaged, contact Restek Corporation or your distributor.



Troubleshooting

1. Problem:	The rotor does not spin freely.
Solutions:	<ul style="list-style-type: none"> • Make sure nothing has fallen into the rotor chamber. • If nothing is obstructing the rotor, contact Restek Corporation or your distributor for further assistance.
2. Problem:	Excessive noise when the machine is running.
Solutions:	<ul style="list-style-type: none"> • Check to see that the load is balanced. • Make sure that nothing has fallen into the rotor chamber. • Make sure that the rotor is installed correctly and that the center thumb screw is tight.
3. Problem:	The centrifuge does not run.
Solutions:	<ul style="list-style-type: none"> • Check the electrical outlet. • Make sure that the power button is depressed. The centrifuge has power when this button is illuminated. • Make sure the lid latch is turned completely clockwise to its stop position. When the lid is closed properly, the latch light on the control panel will illuminate. • Check the circuit breaker switch at the bottom right of the machine. If the switch is white, the breaker has tripped. Contact Restek Corporation or your authorized distributor for assistance. • The printed circuit board may be damaged. Contact Restek Corporation or your distributor for assistance. • The Q-sep™ 3000 centrifuge is equipped with severe out-of-balance detection. If a severely unbalanced load is run, the unit may terminate the run shortly after it begins. Balance the load and restart.
4. Problem:	The latch light does not come on when the lid is closed.
Solutions:	<ul style="list-style-type: none"> • Make sure that the unit has power. • Make sure the lid latch is turned completely clockwise to its stop position. The latch makes contact with a switch underneath the front top of the cabinet. If this switch is not activated, the light will not turn on and the machine will not run.
5. Problem:	The machine does not unlock after a run has completed.
Solutions:	The lid should remain locked until the rotor has come to a complete stop and then unlock for 60 seconds. If additional unlock time is needed, press the "OPEN / EMERGENCY STOP" button with the machine plugged in and the rotor stopped. If the lid remains locked after this and will not unlock, the electronics may have been damaged. Contact Restek Corporation or your authorized distributor. To access the rotor chamber, follow the procedure on page 10, "Emergency Rotor Chamber Entry".
6. Problem:	The run time is not set to the desired length.
Solutions:	Check the preset run time by following the instructions on page 6. If the preset run time is not the desired length, follow the instructions on page 6 to change it.

Replacement Parts for Q-sep™ 3000 Centrifuge

Part No.	Description
26232	50mL single place tube holder (2-pk.)
26233	100mm 4-place tube holder (2-pk.)
26234	2mL tube adapters (4-pk.)
26235	50mL conical tube inserts (6-pk.)



HROMalytic +61(0)3 9762 2034 09
 AUSTRALIAN Distributors **ECHnology** www.chromtech.net.au

Q-sep™ 3000 Centrifuge

Operator's / Service Manual

cat. # 26230 & 26231



WARRANTY

Restek Corporation warrants that this centrifuge is free from defects in materials and workmanship for 5,000 cycles or 12 months, whichever comes first. Should the centrifuge require warranty or out-of-warranty service, please contact Restek Corporation or your local distributor.



ISO 9001:2000
cert.# FM80397

Lit. Cat.# GNOT1203

© 2009 Restek Corporation.