



## Two Position Microelectric Valve Actuator *(Control module serial numbers starting with EM2C)\**

The microelectric actuator consists of a control module, a stepper motor/gearbox assembly, a manual controller (use is optional), a universal AC input (100-240 VAC, 50-60 Hz) to 24 VDC power supply, and the interconnecting cables. The actuator is self-adjusting from 30° to 90° – no valve alignment is necessary. Once a valve is installed by tightening the clamp screw, the actuator senses the positive stops within the valve and memorizes them in the first four moves.

The time it takes a valve to cycle from Position A to Position B depends on the amount of rotation involved. To determine the number of degrees in the angle of rotation, divide 360° by the number of ports in the valve. Then consult the table at right.

	EQ	EH	EP	ED	ET
36°	60	70	90	140	330
45°	70	85	115	175	410
60°	85	110	150	235	500
90°	115	145	235	300	710

Switching times in milliseconds

### Installation and Use

#### Getting Started

**Figure 1** on the next page shows how to connect the various actuator components. There are four connectors on the control module, keyed and sized to prevent incorrect connection.

#### Cable and Connector Functions

*Input power* (20-30 VDC, with 24-28 VDC preferred) is supplied through a coaxial connector: the inner pin is + voltage and the outer pin is ground. The average DC current requirement is 2.5 amps. Standby current draw is 60 milliamps. The actuator should not share a power supply with other noise-sensitive electronics, as the high current draw can cause problems.

*Motor driver output* is through the five-pin connector: pins 1, 2, 4, and 5 carry the stepper motor phase drive signals. Pin 3 is grounded and tied to the cable shield to reduce electrical noise.

A three-pin connector is used for the *RS-232 interface*: pin 1 is ground, pin 2 is transmit to the host computer, and pin 3 is receive from the host. (A discussion on serial control of the actuator starts on page 3.)

The ten-pin connector is for the *manual controller* or for *digital input/output signals*; the actuator can be controlled by *either or both*. The manual controller has a through port, so an additional cable can provide simultaneous control by an external system. (Digital control of the actuator is discussed on page 3.)

Pin #	Signal Description
<b>Input Power Cable</b>	
inner	+20-30 VDC power
outer	Ground
<b>Motor Driver Output Cable</b>	
1	Phase B
2	Phase B
3	Ground
4	Phase A
5	Phase A

\* Serial numbers are on the underside of the control module. (**Figure 2**) Actuators of this series, obsoleted in 2010, are further identified by a metallic control module housing. If your actuator control module has a plastic housing and a serial number starting with E2CA, please refer to Technical Note 421.

Australian Distributors  
 Importers & Manufacturers  
 www.chromtech.net.au  
 +61(0)3 9762 2034  
 HROMalytic  
 ECHnology Pty Ltd  
 Website NEW : www.chromalytic.com.au E-mail : info@chromtech.net.au Tel: 03 9762 2034 . . . IN AUSTRALIA

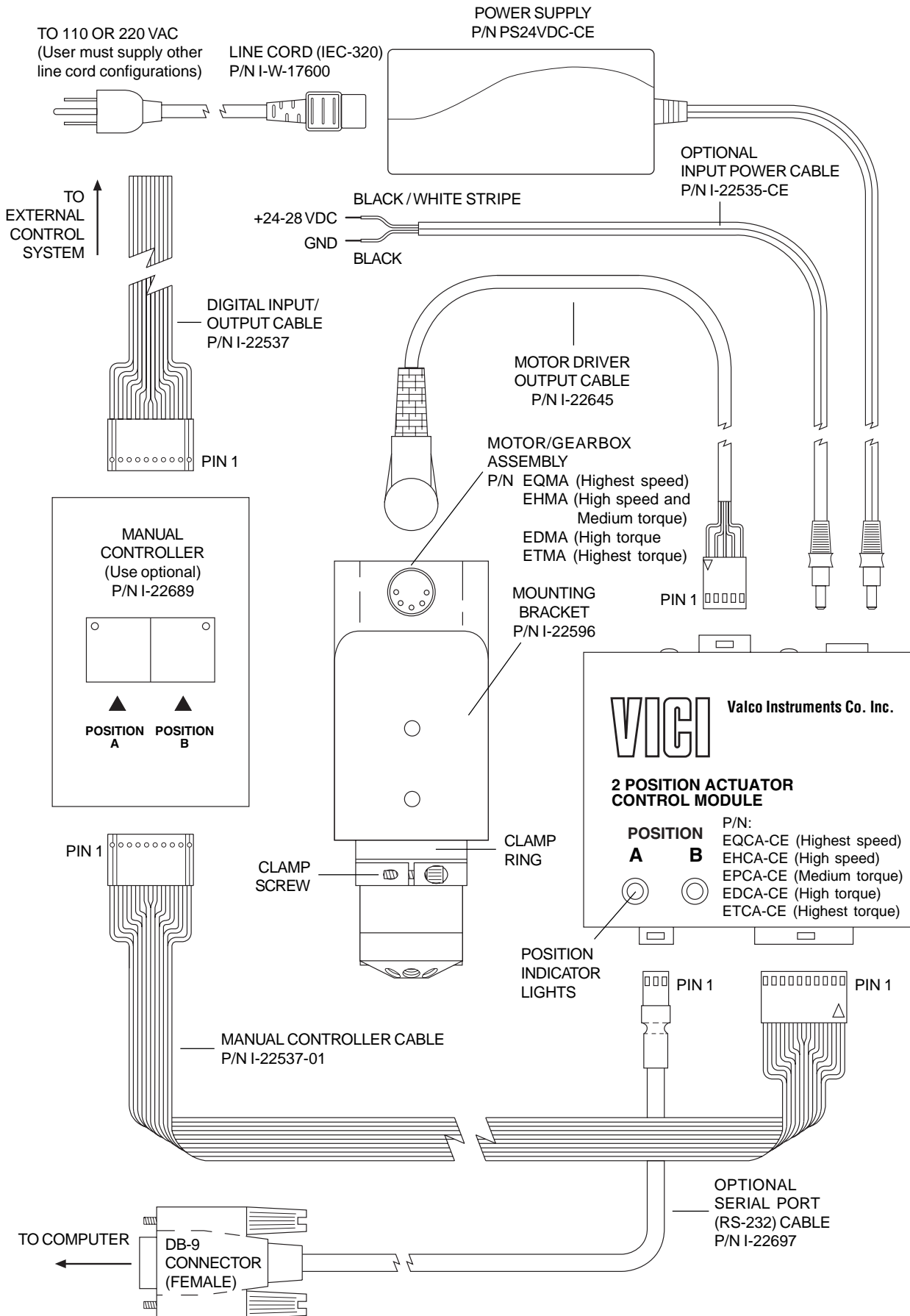
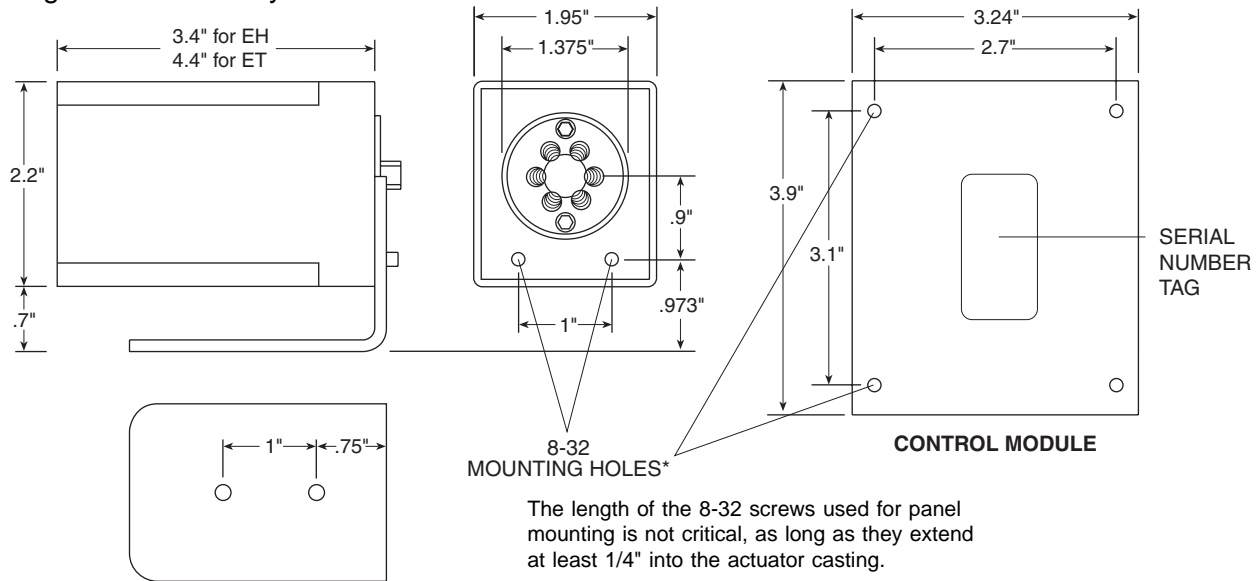
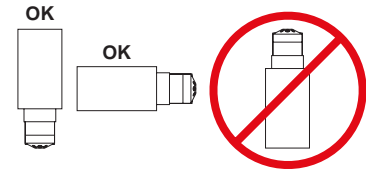

Figure 1: Actuator and controller connections

**Australian Distributors**  
 Importers & Manufacturers  
 www.chromtech.net.au  
**HRomalytic** +61(0)3 9762 2034  
**ECHnology Pty Ltd**  
 Website NEW : www.chromalytic.com.au E-mail : info@chromtech.net.au Tel: 03 9762 2034 . . . in AUSTRALIA

## Mounting

The actuator should be oriented so that any potential leakage of liquid from the valve or fittings flows away from rather than into the actuator. (below) **Figure 2** provides the mounting dimensions for the stepper motor/gearbox assembly.



**Figure 2**

## Initialization

Any time a valve is removed and reinstalled, the actuator must be initialized by following these steps:

1. Cycle the actuator twice with no valve, or with either end of the motor driver output cable unplugged.
2. Plug the cable back in, or put the valve back in the clamp ring. Orient the valve as desired and tighten the clamp screw.

For the next few cycles the actuator will move at half its normal speed while it looks for the valve stops. Once it determines the proper stroke, the actuator will return to normal speed. If you don't hear a change in speed, make sure that the clamp screw is tight.

## Digital Control of the Actuator

### Digital Communication Protocol

Pins 1 and 2 provide ground and +5 volt outputs, respectively; pins 3 and 4 are TTL outputs for Position A and Position B, and are considered asserted at 0 volts and deasserted at 5 volts. (This is sometimes referred to as "negative true logic".) Pins 5 and 6 are digital inputs for switching to Position A and Position B. They can be driven either by 5 volt TTL/CMOS logic or by contact closure to ground (Pin 1). Isolated contact closure outputs are available at Pins 7 and 8 for Position A and Pins 9 and 10 for Position B. If there is a positioning error due to valve sticking, clamp ring slippage, etc., the output is set to "0" (all lines high for a negative true output).

Digital I/O Cable	
Pin #	Signal Description
1	Ground
2	+5 VDC
3	Position A output
4	Position B output
5	Position A input
6	Position B input
7	Position A relay contact output
8	Position A relay contact output
9	Position B relay contact output
10	Position B relay contact output

### Input Modes

Two input mode options are provided to expand the control flexibility of the actuator.

#### Mode 1

In mode 1 (default) the digital inputs are set to be compatible with the standard Valco AC actuator. Asserting input pin 5 causes the actuator to go to Position A, and asserting input pin 6 sends it to

Position B. Operation in this mode requires two relays, as shown in the illustration at right. Relays should be asserted (turned on) for a minimum of 30 msec and deasserted (turned off) for a minimum of 30 msec before the next assertion.

### Mode 2

Operation in this mode requires one relay. In mode 2, asserting pin 5 causes the actuator to toggle from the current to the opposite position. Asserting pin 6 causes the actuator to toggle to the opposite position, delay for a preset period of time (the default is 100 ms), and toggle back to the original position.

### Mode Setup

To set the actuator mode, connect it to an RS-232 serial port as described in the section below, **Establishing Serial Communications**. To see the current setting, enter the **SM** command as shown in the Serial Commands chart on page 5. To change the mode, enter **SMn**, where *n* is 1 or 2. The **DT** command displays the current delay time setting. This setting can be changed with the **DTn** command, where *n* is the desired time from 0 to 65,000 milliseconds.

Mode settings are saved when the power is off.

## Serial Control of the Actuator

### Establishing Serial Communications

Items required:

- Valco cable assembly I-22697 or equivalent
- Terminal emulation or communication software such as QModem, ProComm, or Windows® Terminal or HyperTerminal, running on a PC-compatible computer

1. Connect the I-22697 cable to the actuator as indicated in **Figure 1**, and set the serial port at 9600 baud, no parity, 8 data bits, 1 stop bit, no hardware or software handshaking.
2. With the software running, check the bi-directional communication link between the keyboard/monitor of the computer and the serial port by typing **VR<enter>**. If the link is functioning and an actuator ID has not been set, a message similar to the following will appear on your monitor, giving the program number and date of the actuator firmware.

**I-PD-ETX88RXX** (XX = revision number)

**2 - Aug - 99**

If there is no response, it is possible that the ID has already been set. To force a response from a device with an unknown ID, type **\*VR<enter>**. The asterisk is a substitute ID wild card which will elicit a response from all devices on line, no matter what their ID is.

*Programmer's note:* To permit multiple actuators to share the same computer serial port, the actuator serial port output is deactivated when not in use. At the beginning of a message the first character transmitted is sometimes lost due to a framing error. To avoid this, a NULL character (zero value byte) is sent at the beginning of each message. Most terminal programs will ignore the NULL character, but custom software may require a character trap to delete it.

### Serial Communication Protocol

Serial communication is based on an ASCII string protocol. Carriage return (OD hex) characters parse the communications by defining the end of each command. Line feed characters (OA hex) are ignored. A three-pin connector is used for the RS-232 interface: pin assignments are indicated at right. Software flow control (Xon/Xoff) and hardware handshaking are not supported.

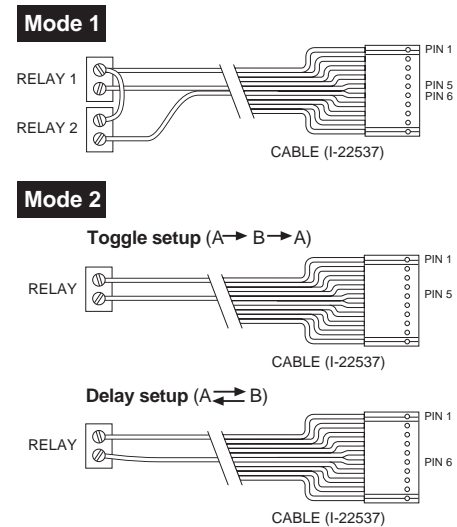

Serial Port (RS-232) Cable	
Pin #	Signal Description
1	Ground
2	Transmit to host
3	Receive from host

Serial Commands	
<b>CP</b> <enter>	Displays the current actuator position
<b>CW</b> <enter>	Sends the actuator to Position A
<b>CC</b> <enter>	Sends the actuator to Position B
<b>GO</b> <i>n</i> <enter>	Sends the actuator to Position <i>n</i> , where <i>n</i> is A or B
<b>TO</b> <enter>	Toggles the actuator to the opposite position
<b>TT</b> <enter>	Toggles the actuator to the opposite position, waits a preset delay time, then rotates back to the original position.
<b>ID</b> <enter>	Displays the current device ID setting
<b>ID</b> <i>n</i> <enter>	Sets the device ID to value <i>n</i> , from 0 to 9 NOTE: When the ID feature is enabled, all commands to the device must be prefaced by the ID number. Entering ID* disables this feature (discussed below.)
<b>ID</b> *<enter>	Clears the ID variable
<b>SB</b> <enter>	Displays the current baud rate
<b>SB</b> <i>nnnn</i> <enter>	Sets the baud rate to 1200, 2400, 4800, 9600 (default), 14400, 19200, 28800, or 38400. The parity setting, number of data bits, and number of stop bits cannot be changed. (See section entitled <b>Setting a New Baud Rate</b> on the next page)
<b>SO</b> <i>nnnn</i> <enter>	Turns off the position outputs after a delay, set in milliseconds to the closest 5 ms interval, from 0 to 30,000 ms. The outputs are <i>always on</i> (SO=0) by default.
<b>SM</b> <enter>	Displays the current digital input mode (See section entitled <b>Digital Control of the Actuator</b> , subhead <b>Input Modes</b> )
<b>SM</b> <i>n</i> <enter>	Sets the digital input mode to Mode <i>n</i> , where <i>n</i> is 1 or 2
<b>DT</b> <enter>	Displays the current delay time in milliseconds
<b>DT</b> <i>n</i> <enter>	Sets the delay time from 0 to 65,000 milliseconds NOTE: The total delay time equals $n = 2$ milliseconds
<b>VR</b> <enter>	Displays the part number and date of the firmware
<b>/?</b> <enter>	Displays list of valid commands
<b>IN</b> <enter>	Starts a re-initialization sequence

With the software-settable device “ID” feature enabled, the serial port output (transmit line) of the actuator is disabled (high impedance). Thus, as many as ten actuators can be controlled from a single host serial port for a temporary multidrop application. For permanent multidrop applications, the RS-485 option is the factory-recommended solution. The table above describes and explains all the commands available.

### Using the Device ID Feature

Actuators are shipped from the factory with this feature disabled. When it’s enabled, the actuator responds only to commands which begin with the correct ID prefix, allowing up to 10 actuators to be controlled from one serial port. A single command can be broadcast to all actuators by using an asterisk (\*) as the command prefix. *Note:* Any broadcast command which elicits a response from the serial port (such as \*VR or \*ID1) will receive a combined and unintelligible response.



To set the ID of an actuator, connect it to an RS-232 serial port as shown in **Figure 1** on page 2. **Caution:** When installing or replacing actuators on a shared serial port, make sure that no two devices have been set to the same ID number.

1. Remove all of the actuators from the serial daisy chain except the one for which you are setting the ID.
2. Type **VR** <enter>. You should get a response giving the firmware version, indicating that serial communication with the actuator is established. If there is no response, type **\*VR**<enter> to see if the ID is already set. If there is still no response, check the cabling and connections.
3. To set an ID, type **IDn**<enter>, where *n* is the new ID, from 0 to 9.  
To change an ID, type **iIDn**<enter>, where *i* is the current ID and *n* is the new ID.  
To disable the ID feature, type **iID\***<enter>, where *i* is the current ID.

### Setting a New Baud Rate

To permanently set a new baud rate for the actuator:

1. Establish communications with the actuator at the current baud rate.
2. Issue the command **SBnnnn** to temporarily change the baud rate to the desired rate. If the power goes down at this point, the baud rate will revert to the last permanent setting.
3. Change the host computer to the same baud rate just set in the actuator, and verify that you can establish communications.
4. Re-issue the same **SBnnnn** command you did previously (in Step 2), and the current baud will be made permanent.

## RS-485 Option

### Software

The RS-485 option involves three minor software adaptations to the RS-232 protocol. The first is that the ID range is extended to include the characters "A" through "Z", with upper and lower cases treated as the same ID. The second change is that the ID is required (either numbers from 0 to 9 or letters from A to Z), and must be included in all commands. The factory-set default ID for all devices is "Z". The third adaptation is that all commands must include a forward slash [/] as the start-of-message character.

### Hardware

The RS-485 hardware includes two 3-pin connectors (**Figure 3**) used as in/out connectors for easy daisy-chaining of additional devices. Wired in parallel, the signal assignments are as follows: Pin 1 is Ground, Pin 2 is Phase B, and Pin 3 is Phase A.

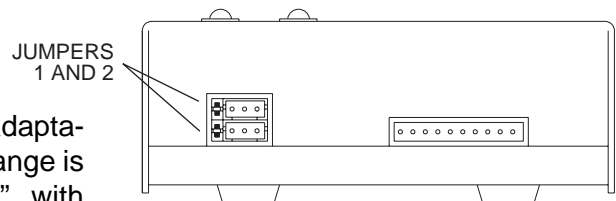

**Figure 3:** Control module,

The four male pins in a vertical row to the left of these connectors are jumper headers, used to add or remove terminating resistors from the communication lines. The top two and the bottom two should be jumpered when termination is required. The RS-485 hardware specifications require termination at each end of the communication line, so in a daisy-chaining application the jumpers should be removed from all the intermediate devices. The RS-485 port on the host computer or controlling device generally includes terminating resistors, so only the actuator on the end of the communication string needs to have the jumpers installed.

North America, South America, and Australia/Oceania contact:

**VICI** Valco Instruments Co. Inc.  
P.O. Box 55603  
Houston, TX 77255  
Sales: (800) 367-8424  
Tech: (713) 688-9345  
Fax: (713) 688-8106 valco@vici.com

Europe, Asia, and Africa contact:

**VICI** VICI AG International  
Parkstrasse 2  
CH-6214 Schenkon  
Switzerland  
Phone: +41 41 925 6200  
Fax: +41 41 925 6201 info@vici.ch

TN-413 Rev 1/11

Cheminert® and VICI® are registered trademarks of Valco Instruments Co. Inc. and VICI AG



## Multiposition Microelectric Valve Actuators

### Models EMH and EMT

The microelectric multiposition actuator consists of a control module, a stepper motor/gearbox assembly, a manual controller (use is optional), a universal AC input (100-240 VAC, 50-60 Hz) to 24 VDC power supply, and the interconnecting cables.

The time it takes to step a valve from one position to another depends upon the actuator model, the number of positions for which the actuator is set, and the total amount of rotation involved. Actual times can be computed from the tables below.

EMH (high speed) actuator		
Number of positions set	Time req. to move one position	Time per additional position
4	332 ms	216 ms
6	260 ms	149 ms
8	220 ms	111 ms
10	200 ms	87 ms
12	188 ms	72 ms
16	166 ms	54 ms

EMT (high torque) actuator		
Number of positions set	Time req. to move one position	Time per additional position
4	1161 ms	999 ms
6	831 ms	663 ms
8	665 ms	496 ms
10	563 ms	399 ms
12	497 ms	333 ms
16	412 ms	251 ms

**NOTE:** With the exception of Valco P type valves (which have a visible coil spring), all our multiposition valves are keyed to provide automatic alignment on a microelectric actuator. However, not all standoffs (an extension which holds the valve away from the actuator) are keyed. Therefore, if you are ordering components separately or retrofitting a valve and actuator with a standoff, make sure you specify a keyed standoff so that you can take full advantage of the ease of alignment provided by a keyed standoff, microelectric actuator, and valve.

## Installation and Use

### Getting Started

**Figure 1** on the next page shows the functions of the cables supplied with the actuator. There are four connectors on the control module, keyed and sized to prevent incorrect connection.

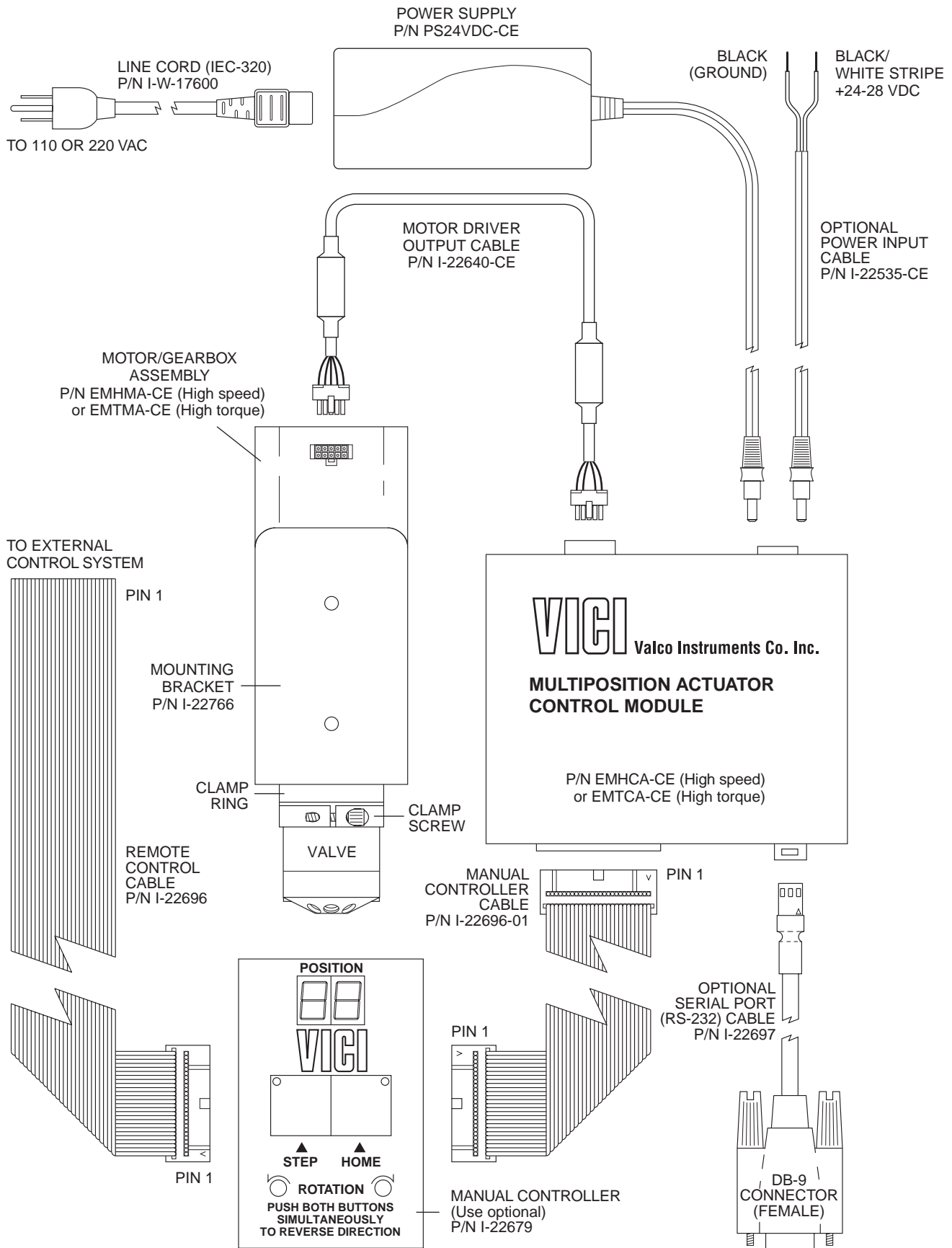

**Australian Distributors**  
 Importers & Manufacturers  
 www.chromtech.net.au  
**HRomalytic** +61(0)3 9762 2034  
**ECH nology** Pty Ltd  
 Website NEW : www.chromalytic.com.au E-mail : info@chromtech.net.au Tel: 03 9762 2034 . . . in AUSTRALIA

**Figure 1: Actuator and controller connections**



## Mounting

The actuator should be oriented so that any potential leakage of liquid from the valve or fittings flows away from rather than into the actuator. (below) **Figure 2** provides the mounting dimensions for the stepper motor/gearbox assembly.

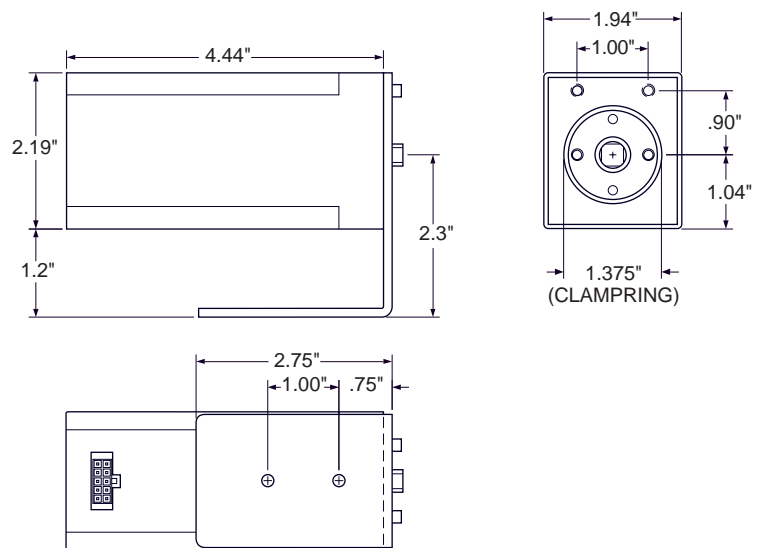
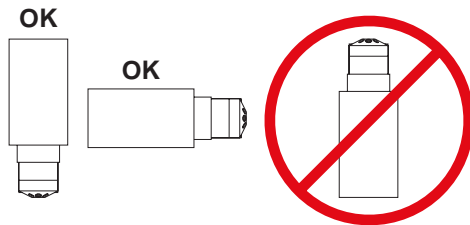

Figure 2: Mounting dimensions



## Cable and Connector Functions

Input power (20 – 30 VDC, with 24 – 28 VDC preferred) is supplied through a miniature power connector: the inner pin is + voltage and the outer is ground. Average DC current requirement is 2.5 amps. Standby current is less than 100 milliamps. The actuator should not share a power supply with other noise-sensitive electronics, as the high current draw can cause problems.

Motor driver output is through the 10 pin connector. The 26-pin connector is for the manual controller and remote digital input/output signals; the actuator can be controlled by *either* or *both*. The manual controller has a pass-through port, so an additional cable can provide simultaneous control by an external system. The three-pin connector is for RS-232 interface. The serial and digital functions are fully described on pages 4 - 8.

## Manual Controller

The manual controller allows the user to select the rotation direction, set the total number of positions, and control the STEP and HOME functions. The controller is connected to the actuator control module with the 26 pin ribbon cable. The manual controller has two functional modes – the operating mode and the setup mode. The display indicates the current position in the operating mode, the total number of positions in the setup mode, and an “EP” when there is a positioning error.

## Operating Mode

This is the default mode; that is, the controller will be in this mode when it is initially powered. In this mode the STEP and HOME functions are clearly labelled as the primary functions of the left and right switches, respectively. To change the direction of rotation, momentarily depress the STEP and HOME switches simultaneously. The DIRECTION LEDs will change, indicating that the direction has reversed.

## Setup Mode

To shift into the setup mode, depress the STEP and HOME switches and hold them down for 8 seconds. The position display LEDs will begin to flash, displaying the current setting for the total number of positions in a full rotation. Use the STEP switch to increase or the HOME switch to decrease this setting to the desired number of positions. To return to the operating mode, depress both switches until the LEDs stop blinking.

## Simultaneous Use of the Manual Controller and an External Control System

The manual controller has two identical connectors for input and/or output, permitting an external system to be used simultaneously with the manual STEP and HOME commands. However, *the following precaution should be observed:*

If the STEP and HOME functions are to be used by *both* systems, the external system control output cannot be in the form of TTL signals; instead, the output must be a momentary signal asserted by a contact closure or open collector driver. While TTL signals will cause no damage to either system, they will effectively override the manual controller.

### Connecting External Systems

An external control system can be connected to the actuator in several ways:

1. The Digital Input/Output connector is a 26 pin dual in-line connector which can mate to a mass terminatable flat cable connector available from a number of manufacturers. The flat cable can then be integrated into the control system.
2. The manual controller can be connected to the control module, and then a 26 pin dual in-line connector and flat cable assembly can be attached to the manual controller. This allows dual control as well as a visual indication of the actuator position.
3. A serial port can be connected from a host control system to the actuator, using the optional RS-232 cable (Product No. I-22697).

### Digital Protocols

#### Hardware Input / Output Protocols

Digital input/output control of the multiposition actuator is designed for simplicity and flexibility of function. The simplest control of the actuator can be accomplished with two output control lines – STEP and HOME. The chart on the next page lists other control options.

The **inputs** are held to a logical high (+5 volts) by pull-up resistors, and are designed to be driven low either by contact closure, 5 volt digital logic, or open collector transistor outputs. The signal polarity is defined as “negative true” – asserting the signal involves shorting the signal (in the case of contact closure) or driving it (in the case of logic or transistor signals) to within 0.8 volts of ground potential. These input signals must be at least 30 milliseconds in duration. The **outputs** are also “negative true” signals driven by standard high speed CMOS gates, capable of driving standard logic input gates. They include the BCD position, motor run, rotational direction, and error signals. If the actuator stops out of position due to a stuck valve, the BCD output is set to “0” (all lines high for a negative true output).

The digital interface is made through a 26 pin connector which also provides power (+5 volts/100 ma maximum) and ground outputs. The ground should be connected to the control system to maintain commonality between the actuator and the controlling device. If you intend to provide your own power supply, make sure that it has an isolated output or that it shares a common ground with the controlling system.

#### Software Input Protocols

*(chart on next page, discussion on page 6)*

Pin	Color	Signal	Direction	Pin	Color	Signal	Direction
1	brown	Home	Input	14	yellow	4 BCD	Output
2	red	Motor run	Output	15	green	20 BCD	Output
3	orange	Step	Input	16	blue	2 BCD	Output
4	yellow	Error	Output	17	violet	10 BCD	Output
5	green	Manual Dir.	Input	18	gray	1 BCD	Output
6	blue	Direction	Output	19	white	80 BCD	Input
7	violet	Auto Dir.	Input	20	black	8 BCD	Input
8	gray	Data latch	Input	21	brown	40 BCD	Input
9	white	+5 VDC 100 ma	Output	22	red	4 BCD	Input
10	black	Ground	Output	23	orange	20 BCD	Input
11	brown	80 BCD	Output	24	yellow	2 BCD	Input
12	red	8 BCD	Output	25	green	10 BCD	Input
13	orange	40 BCD	Output	26	blue	1 BCD	Input

**Pin signal definitions for the Digital Input/Output cable**

Mode:	SD0	SD2	SD3	Data Input Lines									
Input type:	BCD	Parallel	Binary	1 BCD	2 BCD	4 BCD	8 BCD	10 BCD	20 BCD	40 BCD	80 BCD		
Position:	1	1	1	X	—	—	—	—	—	—	—		
	2	2	2	—	X	—	—	—	—	—	—		
	3	*	3	X	X	—	—	—	—	—	—		
	4	3	4	—	—	X	—	—	—	—	—		
	5	*	5	X	—	X	—	—	—	—	—		
	6	*	6	—	X	X	—	—	—	—	—		
	7	*	7	X	X	X	—	—	—	—	—		
	8	4	8	—	—	—	X	—	—	—	—		
	9	*	9	X	—	—	X	—	—	—	—		
	*	*	10	—	X	—	X	—	—	—	—		
	*	*	11	X	X	—	X	—	—	—	—		
	*	*	12	—	—	X	X	—	—	—	—		
	*	*	13	X	—	X	X	—	—	—	—		
	*	*	14	—	X	X	X	—	—	—	—		
	*	*	15	X	X	X	X	—	—	—	—		
	10	5	16	—	—	—	—	X	—	—	—		
	11	*	17	X	—	—	—	X	—	—	—		
	12	*	18	—	X	—	—	X	—	—	—		
	13	*	19	X	X	—	—	X	—	—	—		
	14	*	20	—	—	X	—	X	—	—	—		
	15	*	21	X	—	X	—	X	—	—	—		
	16	*	22	—	X	X	—	X	—	—	—		
	17	*	23	X	X	X	—	X	—	—	—		
	18	*	24	—	—	—	X	X	—	—	—		
	19	*	25	X	—	—	X	X	—	—	—		
	*	*	26	—	X	—	X	X	—	—	—		
	*	*	27	X	X	—	X	X	—	—	—		
	*	*	28	—	—	X	X	X	—	—	—		
	*	*	29	X	—	X	X	X	—	—	—		
	*	*	30	—	—	X	X	X	—	—	—		
	*	*	31	X	X	X	X	X	—	—	—		
	20	6	32	—	—	—	—	—	X	—	—		
				<i>Code sequence break</i>									
	40	7	64	—	—	—	—	—	—	X	—		
				<i>Code sequence break</i>									
	80	8	128	—	—	—	—	—	—	—	X		

**Pin signal definitions for the various input modes**

**HRomalytic** +61(0)3 9762 2034  
**ECH nology Pty Ltd**  
 Website NEW : www.chromalytic.com.au E-mail : info@chromotech.net.au Tel: 03 9762 2034 . . . in AUSTRALIA  
 Australian Distributors Importers & Manufacturers www.chromotech.net.au

## Software Input Protocols

The input modes are selected by the serial port command “SDn”, with  $n = 0, 1, 2,$  or  $3$ . Mode information is stored in non-volatile memory and maintained during power up/down sequences. The modes are:

- SD0** (default) Binary Coded Decimal (BCD) input mode. For the 96 possible input positions, all 8 digital input data lines are required. Refer to the chart on the previous page for the signal line definitions.
- SD1** Disables the digital inputs to prevent user intervention during automated control via the serial port. It resets to SD0 during the power up sequence.
- SD2** Redefines the data input lines so that each input line equates to only one actuator position; any and all combinations of data input lines are invalid. This mode can support *only 8 positions*: 1 BCD = position 1; 2 BCD = position 2; 4 BCD = position 3; 8 BCD = position 4; 10 BCD = position 5; 20 BCD = position 6; 40 BCD = position 7; and 80 BCD = position 8. The offset value **SO** is set to 1, and since the number of positions is limited to 8, any user-set **NP** value greater than 8 will revert to 8. (See the chart on the next page for more explanation of **NP** and **SO**.)
- SD3** Redefines the data input lines to a binary input instead of BCD. This reduces the number of input lines required to select positions above 9. For example, BCD mode inputs for any position between 10 and 15 requires the use of data input lines 1, 2, 4, 8, and 10 BCD. In the binary mode, only lines 1, 2, 4, and 8 BCD are required. The position values for the binary mode are calculated the same way as those for the BCD mode, except that all combinations of the input lines are valid numerical positions.

## Serial Control of the Actuator

### Establishing Serial Communications

*Items required:*

- Valco cable assembly I-22697 or equivalent
- Terminal emulation or communication software such as QModem, ProComm Plus™, or HyperTerminal® (included with Windows®), running on a PC-compatible computer

1. Connect the I-22697 cable to the actuator as indicated in **Figure 1**, and set the serial port at 9600 baud, no parity, 8 data bits, 1 stop bit, no hardware or software handshaking.
2. With the software running, check the bi-directional communication link between the keyboard/monitor of the computer and the serial port by typing **VR**<enter>. If the link is functioning and an actuator ID has not been set, a message similar to the following will appear on your monitor, giving the program number and date of the actuator firmware.

**I-PD-ETX88RXX** (XX = revision number)  
**2 - Aug - 99**

If there is no response, it is possible that the ID has already been set. To force a response from a device with an unknown ID, type **\*VR**<enter>. The asterisk is a substitute ID wild card which will elicit a response from all devices on line, no matter what their ID is.

*Programmer's note:* In order for multiple RS-232 slave devices to be controlled from one serial port, they must all keep their outputs deactivated until they need to respond. When a device responds, it asserts its output low for 2 milliseconds before sending the first character to clear the host UART's input. Nevertheless, it is possible that the UART will sense a framing error or receive a bogus character. The programmer should be prepared to handle this possibility in software.

Serial Commands	
<b>NP</b> <enter>	Displays the number of positions the actuator is currently set to index
<b>NP</b> <i>nn</i> <enter>	Sets the number of positions ( <i>nn</i> ) for the current valve
<b>CW</b> <i>nn</i> <enter>	Sends the actuator clockwise to position <i>nn</i> (from 1 to NP)
<b>CC</b> <i>nn</i> <enter>	Sends the actuator counterclockwise to position <i>nn</i> (from 1 to NP)
<b>GO</b> <i>nn</i> <enter>	Sends the actuator to position <i>nn</i> (from 1 to NP) via the shortest route
<b>CP</b> <enter>	Displays the current position
<b>SD</b> <enter>	Displays the digital input status where 0 = enabled and 1 = disabled
<b>SD</b> <i>n</i> <enter>	Sets the digital input status to [0] BCD, [1] disabled, [2] parallel, or [3] binary. NOTE: Setting the status to [1] locks out communication through the manual controller and remote control cables, so digital input status defaults to [0] at power up.
<b>SM</b> <enter>	Displays the current default rotational direction for the digital inputs.
<b>SM</b> / <i>&lt;enter&gt;</i>	Sets the default rotational direction for the digital inputs to [F] for forward rotation, [R] for reverse rotation, or [A] to automatically choose the shortest route. This feature can be used instead of external wiring tied to the Manual and/or Autodirection input lines on the Digital I/O port.
<b>ID</b> <enter>	Displays the current device ID setting
<b>ID</b> <i>n</i> <enter>	Sets the device ID to value <i>n</i> , from 0 to 9 NOTE: When the ID feature is enabled, all commands to the device must be prefaced by the ID. Entering ID* clears the ID.
<b>SB</b> <enter>	Displays the current baud rate
<b>SB</b> <i>nnnn</i> <enter>	Sets the baud rate to 1200, 2400, 4800, 9600 (default), 14400, 19200, 28800, or 38400. The parity setting, number of data bits, and number of stop bits cannot be changed. (See section entitled <b>Setting a New Baud Rate</b> on the next page)
<b>SL</b> <enter>	Displays current Data Latch signal status
<b>SL</b> <i>n</i> <enter>	This command displays or changes the requirement for a Data Latch signal to accompany BCD inputs. When set to [0] (factory default), the data latch is required for BCD inputs. When set to [1], the data latch is NOT required. This feature can reduce the number of control lines required for a system with a dedicated BCD output port and only one actuator connected. NOTE: Be sure all the BCD inputs are asserted within 20 milliseconds of each other or the actuator may be misdirected.
<b>SO</b> <enter>	Displays the current offset value
<b>SO</b> <i>nn</i> <enter>	Sets the offset value of the first position to be any number from 1 to 96 minus the total number of positions. Example: for a 10 position valve, the offset can be set from 1 to 86. (See section entitled <b>Using the Offset Feature</b> beginning on the next page.)
<b>VR</b> <enter>	Displays the part number and date of the firmware
<b>/?</b> <enter>	Displays a list of valid commands

**Note:** In this chart, *nn* represents numbers to be entered and *l* represents letters.



## Serial Communication Protocol

Serial communication is based on an ASCII string protocol. Carriage return (OD hex) characters parse the communications by defining the end of each command. Line feed characters (OA hex) are ignored. A three-pin connector is used for the RS-232 interface: pin assignments are indicated at right. Software flow control (Xon/Xoff) and hardware handshaking are not supported.

Serial Port (RS-232) Cable	
Pin #	Signal Description
1	Ground
2	Transmit to host
3	Receive from host

With the software-settable device "ID" feature enabled, the serial port output (transmit line) of the actuator is disabled (high impedance). Thus, as many as ten actuators can be controlled from a single host serial port for a temporary multidrop application. For permanent multidrop applications, the RS-485 option is the factory-recommended solution. The table on the previous page describes and explains all the commands available.

### Using the Device ID Feature

Actuators are shipped from the factory with this feature disabled. When it's enabled, the actuator responds only to commands which begin with the correct ID prefix, allowing up to 10 actuators to be controlled from one serial port. A single command can be broadcast to all actuators by using an asterisk (\*) as the command prefix. *Note:* Any broadcast command which elicits a response from the serial port (such as \*VR or \*ID1) will receive a combined and unintelligible response.

**To set the ID of an actuator**, connect it to an RS-232 serial port as shown in **Figure 1** on page 2. **Caution:** *When installing or replacing actuators on a shared serial port, make sure that no two devices have been set to the same ID number.*

1. Remove all of the actuators from the serial daisy chain except the one for which you are setting the ID.
2. Type **VR** <enter>. You should get a response giving the firmware version, indicating that serial communication with the actuator is established. If there is no response, type **\*VR**<enter> to see if the ID is already set. If there is still no response, check the cabling and connections.
3. To *set* an ID, type **IDn**<enter>, where *n* is the new ID, from 0 to 9.  
To *change* an ID, type **iIDn**<enter>, where *i* is the current ID and *n* is the new ID.  
To *disable* the ID feature, type **iID\***<enter>, where *i* is the current ID.

### Setting a New Baud Rate

To permanently set a new baud rate for the actuator:

1. Establish communications with the actuator at the current baud rate.
2. Issue the command **SBnnnn** to temporarily change the baud rate to the desired rate. If the power goes down at this point, the baud rate will revert to the last permanent setting.
3. Change the host computer to the same baud rate just set in the actuator, and verify that you can establish communications.
4. Re-issue the same **SBnnnn** command you did previously (in Step 2), and the current baud will be made permanent.

### Using the Offset Feature

This feature makes it possible to control more than one actuator without increasing the number of BCD input lines. The actuator's SO value can be set from "1" to "96", minus the current NP value (the number of positions the actuator is set to index). Once an SO value is set, that value is the first (or lowest) position an actuator will recognize. The factory SO setting is "1", so an actuator with an NP value of 10 responds to move commands for positions "1" to "10". If the SO value is changed to "10",

the actuator will respond only to move commands for positions “10” through “19”. For any setting of SO and NP, the lowest valid position will be the SO value and the highest valid position will be the SO value plus the NP value minus 1; *i.e.*, the actuator will respond to commands for position SO through position {SO + NP - 1}.

Here is an example of how this can be used to set up a 31-stream stream selection system using six dedicated BCD lines and two 16-position valves and actuators. First, use the serial port command “SL1” to enable the auto-latching feature on both actuators. (This eliminates the need for a data latch signal.) Configure the second actuator using the serial port command “SO16”, giving it a valid position range of 16 to 31. Use a piece of tubing to connect port 16 of the first valve (on the actuator with the SO value still at the factory setting of “1”) to the common port of the valve on the second actuator (which now has the SO set to “16”). Connect streams 1 through 15 to ports 1 through 15 on the first valve, and streams 16 through 31 to ports 1 through 15 on the second valve.

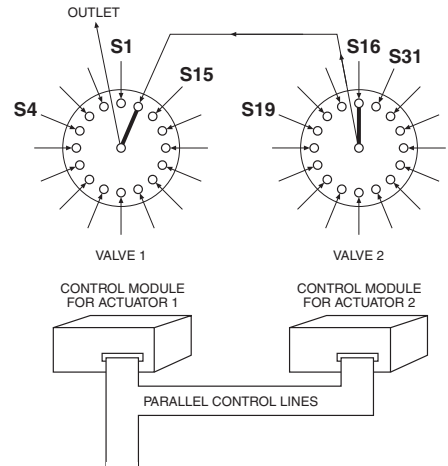

**Figure 3:** Use of the offset feature

This system will step *sequentially* from 1 through 31 with a single BCD instruction. However, when positions are selected in a *random* sequence, position 16 must always be requested before any positions higher 16 are selected. **Figure 3** helps illustrate this: since both actuators respond to a command to go to position 16, stream 16 will flow through valve 1/port 1, out the common port of valve 2, into valve 1/port 16, and out of the common port of valve 1. Thereafter, any stream select command that is above 16 will move only valve 2; when a move command for a position less than 16 is given, valve 1 will move and cut off all flow from valve 2.

## RS-485 Option

### Software

The RS-485 option involves three minor software adaptations to the RS-232 protocol. The first is that the ID range is extended to include the characters “A” through “Z”, with upper and lower cases treated as the same ID. The second change is that the ID is required (either numbers from 0 to 9 or letters from A to Z), and must be included in all commands. The factory-set default ID for all devices is “Z”. The third adaptation is that all commands must include a forward slash [/] as the start-of-message character.

### Hardware

The RS-485 hardware includes two 3-pin connectors (**Figure 4**) used as in/out connectors for easy daisy-chaining of additional devices. Wired in parallel, the signal assignments are as follows: Pin 1 is Ground, Pin 2 is Phase B, and Pin 3 is Phase A.

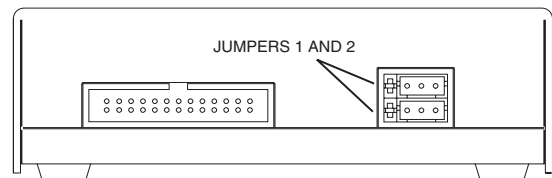

**Figure 4:** Control module, showing jumper locations

The four male pins in a vertical row to the left of these connectors are jumper headers, used to add or remove terminating resistors from the communication lines. The top two and the bottom two should be jumpered when termination is required. The RS-485 hardware specifications require termination at each end of the communication line, so in a daisy-chaining application the jumpers should be removed from all the intermediate devices. The RS-485 port on the host computer or controlling device generally includes terminating resistors, so only the actuator at the far end of the communication string needs to have the jumpers installed.

North America, South America, and Australia/Oceania contact:

**VICI® Valco Instruments Co. Inc.**  
 P.O. Box 55603  
 Houston, TX 77255  
 Sales: (800) 367-8424  
 Tech: (713) 688-9345  
 Fax: (713) 688-8106 valco@vici.com

Europe, Asia, and Africa contact:

**VICI® VICI AG International**  
 Parkstrasse 2  
 CH-6214 Schenkon  
 Switzerland  
 Phone: +41 41 925 6200  
 Fax: +41 41 925 6201 info@vici.ch

Cheminert® and VICI® are registered trademarks of Valco Instruments Co. Inc. and VICI AG

TN-415 10/14

**HRomalytic** +61(0)3 9762 2034  
**ECH nology Pty Ltd**  
 Website NEW : www.chromalytic.com.au E-mail : info@chromtech.net.au Tel: 03 9762 2034 . . . in AUSTRALIA  
 Australian Distributors Importers & Manufacturers www.chromtech.net.au

# VICI Valco Instruments Co. Inc.



## Multiposition Microelectric Valve Actuators

Models EMH and EMT

### Quick Start Guide

The microelectric multiposition actuator consists of a control module, a stepper motor/gearbox assembly, a manual controller (use is optional), a universal AC input (100-240 VAC, 50-60 Hz) to 24 VDC power supply, and the interconnecting cables.

### Cable and Connector Functions

**Figure 1** on the next page shows the functions of the cables supplied with the microelectric actuator. There are four connectors on the control module, keyed and sized to prevent incorrect connection.

Input power (20 – 30 VDC, with 24 – 28 VDC preferred) is supplied through a miniature power connector: the inner pin is + voltage and the outer is ground. Average DC current requirement is 2.5 amps. Standby current is less than 100 milliamps. The actuator should not share a power supply with other noise-sensitive electronics, as the high current draw can cause problems.

Motor driver output is through the 10 pin connector. The 26-pin connector is for the manual controller and remote digital input/output signals; the actuator can be controlled by *either or both*. The manual controller has a pass-through port, so an additional cable can provide simultaneous control by an external system. The three-pin connector is for RS-232 interface. The serial and digital functions are fully described in Technical Note 415, available from Valco or from the support section of our website at [www.vici.com](http://www.vici.com).

### Mounting

The actuator should be oriented so that any potential leakage of liquid from the valve or fittings flows away from rather than into the actuator, as indicated below.

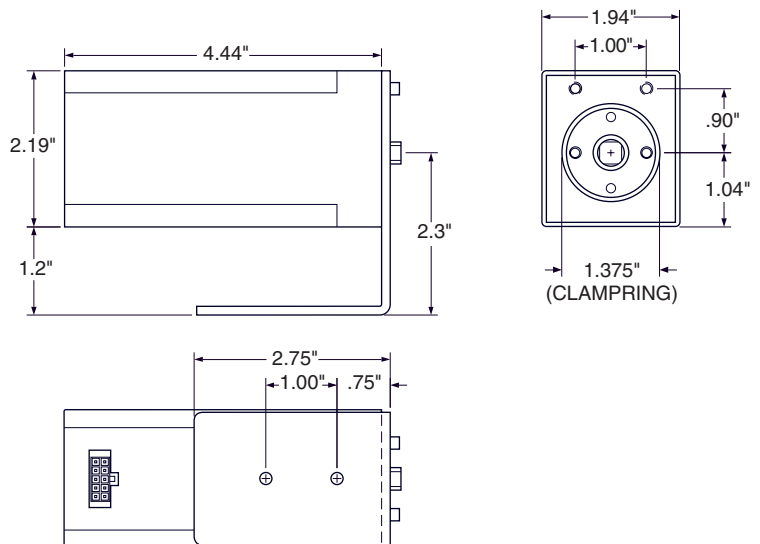
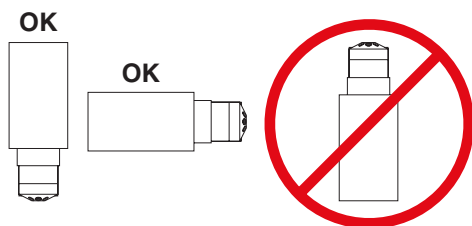

**Australian Distributors**  
 Importers & Manufacturers  
[www.chromtech.net.au](http://www.chromtech.net.au)  
 Tel: 03 9762 2034 . . . in AUSTRALIA  
**HRomalytic** +61(0)3 9762 2034  
**ECH nology Pty Ltd**  
 Website NEW : [www.chromalytic.com.au](http://www.chromalytic.com.au) E-mail : [info@chromtech.net.au](mailto:info@chromtech.net.au)

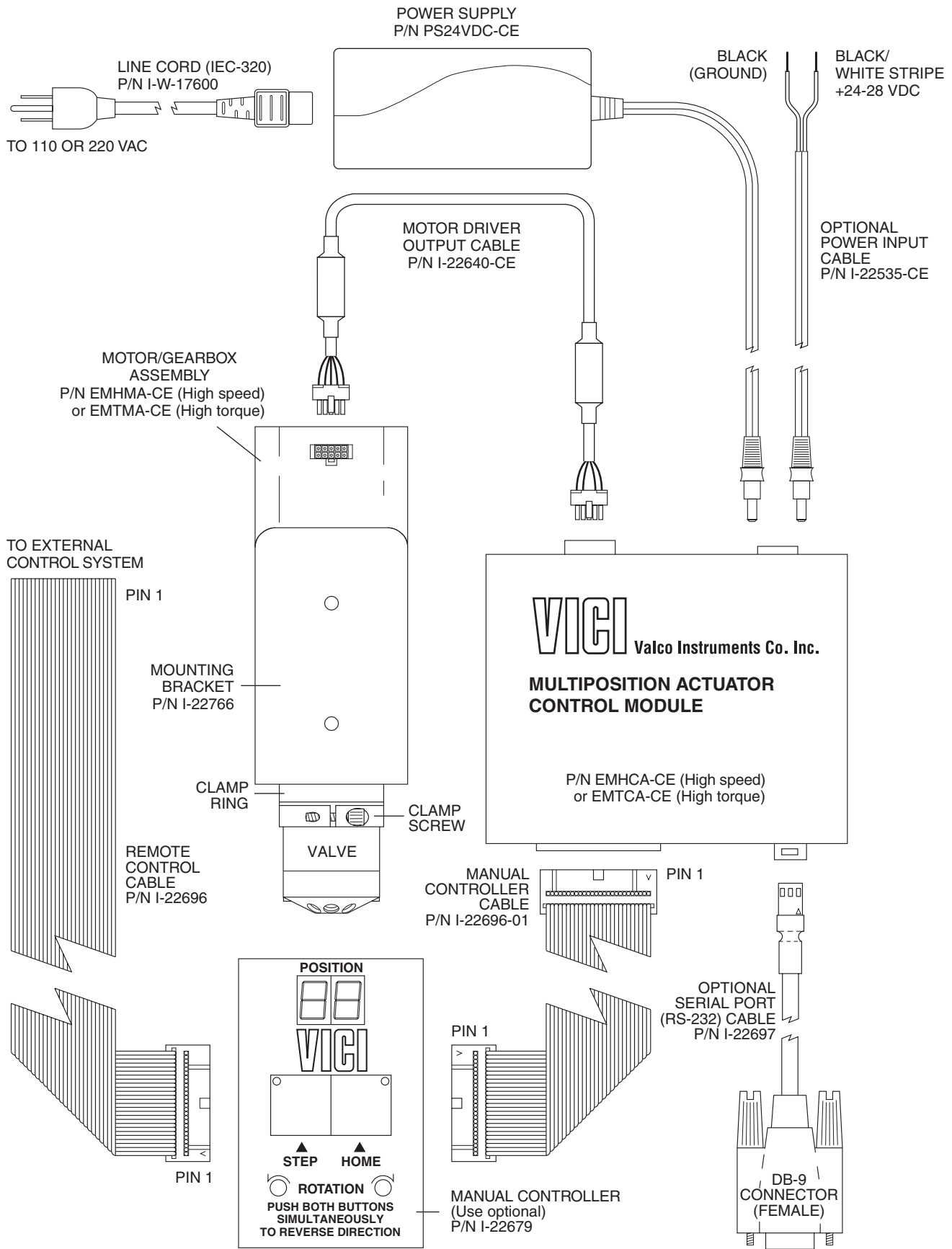

**Australian Distributors**  
 Importers & Manufacturers  
 www.chromtech.net.au  
**HRomalytic** +61(0)3 9762 2034  
**ECH nology** Pty Ltd  
 Website NEW : www.chromalytic.com.au E-mail : info@chromtech.net.au Tel: 03 9762 2034 . . . in AUSTRALIA

**Figure 1: Actuator and controller connections**

Pin	Color	Signal	Direction	Pin	Color	Signal	Direction
1	brown	Home	Input	14	yellow	4 BCD	Output
2	red	Motor run	Output	15	green	20 BCD	Output
3	orange	Step	Input	16	blue	2 BCD	Output
4	yellow	Error	Output	17	violet	10 BCD	Output
5	green	Manual Dir.	Input	18	gray	1 BCD	Output
6	blue	Direction	Output	19	white	80 BCD	Input
7	violet	Auto Dir.	Input	20	black	8 BCD	Input
8	gray	Data latch	Input	21	brown	40 BCD	Input
9	white	+5 VDC 100 ma	Output	22	red	4 BCD	Input
10	black	Ground	Output	23	orange	20 BCD	Input
11	brown	80 BCD	Output	24	yellow	2 BCD	Input
12	red	8 BCD	Output	25	green	10 BCD	Input
13	orange	40 BCD	Output	26	blue	1 BCD	Input

**Pin signal definitions for the Digital Input/Output cable**

## Manual Controller

The manual controller allows the user to select the rotation direction, set the total number of positions, and control the STEP and HOME functions. The controller is connected to the actuator control module with the 26 pin ribbon cable. The manual controller has two functional modes – the operating mode and the setup mode. The display indicates the current position in the operating mode, the total number of positions in the setup mode, and an “EP” when there is a positioning error.

### Operating Mode

This is the default mode; that is, the controller will be in this mode when it is initially powered. In this mode the STEP and HOME functions are clearly labelled as the primary functions of the left and right switches, respectively. To change the direction of rotation, momentarily depress the STEP and HOME switches simultaneously. The DIRECTION LEDs will change, indicating that the direction has reversed.

### Setup Mode

To shift into the setup mode, depress the STEP and HOME switches and hold them down for 8 seconds. The position display LEDs will begin to flash, displaying the current setting for the total number of positions in a full rotation. Use the STEP switch to increase or the HOME switch to decrease this setting to the desired number of positions. To return to the operating mode, depress both switches until the LEDs stop blinking.



## Simultaneous Use of the Manual Controller and an External Control System

The manual controller has two identical connectors for input and/or output, permitting an external system to be used simultaneously with the manual STEP and HOME commands. However, *the following precaution should be observed:*

If the STEP and HOME functions are to be used by *both* systems, the external system control output cannot be in the form of TTL signals; instead, the output must be a momentary signal asserted by a contact closure or open collector driver. While TTL signals will cause no damage to either system, they will effectively override the manual controller.

### Connecting External Systems

An external control system can be connected to the actuator in several ways:

1. The Digital Input/Output connector is a 26 pin dual in-line connector which can mate to a mass terminatable flat cable connector available from a number of manufacturers. The flat cable can then be integrated into the control system.
2. The manual controller can be connected to the control module, and then a 26 pin dual in-line connector and flat cable assembly can be attached to the manual controller. This allows dual control as well as a visual indication of the actuator position.
3. A serial port can be connected from a host control system to the actuator, using the optional RS-232 cable (Product No. I-22697).

### Connections for Remote Control

The remote control cable (I-22696) can be connected to your TTL or contact closure relays to provide automated remote control of the actuator. Be sure to refer to your systems manual to make certain that the relays you plan to use are TTL (5 volts max.) or dry contact closure. Using a powered relay with >5 volts may result in damage to the controller.

For STEP control, connect Pin 10 (the black wire closest to Pin 1) to one relay terminal and Pin 3 (the orange wire closest to Pin 1) to the other terminal. (*Refer to Figures 1 and 2 as required.*)

For HOME control, connect Pin 10 (the black wire closest to Pin 1) to one relay terminal and Pin 1 (the brown wire) to the other terminal.

A momentary closure (50 msec minimum) of the relay will STEP or HOME (Position 1) the actuator. The relay should be turned off with 5 seconds of being turned on to properly enable the manual override function of the manual controller.

### For More Information

For detailed information on digital control, serial control, switching times, and other optional features, refer to Technical Note 415 in the support section of [www.vici.com](http://www.vici.com), or request a copy by calling 713-688-9345 or (int) +41-41-925-6200.

North America, South America, and Australia/Oceania contact:

**VICI** Valco Instruments Co. Inc.  
P.O. Box 55603  
Houston, TX 77255  
Sales: (800) 367-8424  
Tech: (713) 688-9345  
Fax: (713) 688-8106 [valco@vici.com](mailto:valco@vici.com)

Europe, Asia, and Africa contact:

**VICI** VICI AG International  
Parkstrasse 2  
CH-6214 Schenkon  
Switzerland  
Phone: +41 41 925 6200  
Fax: +41 41 925 6201 [info@vici.ch](mailto:info@vici.ch)

Cheminert® and VICI® are registered trademarks of Valco Instruments Co. Inc. and VICI AG

TN-415QS 10/14